

Tinned Copper Tape

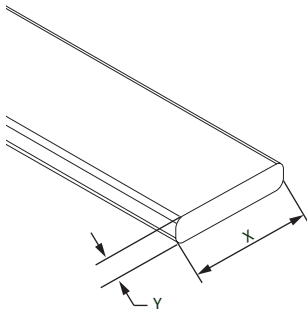

Kingsmill **Tinned Copper Tape** is embossed 'Kingsmill (UK)' for identification purposes and is manufactured from high conductivity annealed copper.

Tinned Copper Tape is sold in the specified coil lengths only.

CONDUCTOR SIZE (X x Y) (mm)	CSA (mm ²)	COIL SIZE (m)	WEIGHT (kg/m)	PART NO.
12.5 x 1.5	18.75	100	0.17	TCTD1215
12.5 x 3	37.5	100	0.33	TCTD1230
20 x 1.5	30	100	0.27	TCTD2015
20 x 3	60	100	0.53	TCTD2030
25 x 1.5	37.5	100	0.33	TCTD2515
25 x 3	75	50	0.67	TCTD2530
25 x 4	100	50	0.89	TCTD2540
25 x 6	150	40	1.34	TCTD2560
30 x 2	60	50	0.53	TCTD3020
30 x 3	90	50	0.80	TCTD3030
30 x 4	120	40	1.07	TCTD3040
30 x 5	150	40	1.33	TCTD3050
31 x 3	93	50	0.83	TCTD3130
31 x 6	186	30	1.65	TCTD3160
38 x 3	114	50	1.01	TCTD3830
38 x 5	190	30	1.69	TCTD3850
38 x 6	228	25	2.03	TCTD3860
40 x 3	120	40	1.06	TCTD4030
40 x 4	160	30	1.42	TCTD4040
40 x 5	200	25	1.78	TCTD4050
40 x 6	240	25	2.13	TCTD4060
50 x 3	150	40	1.33	TCTD5030
50 x 4	200	30	1.78	TCTD5040
50 x 5	250	20	2.22	TCTD5050
50 x 6	300	20	2.68	TCTD5060

Material: Tinned Copper

Standard: BS:EN 13601 (formerly BS 1432)

Galvanised Steel Tape

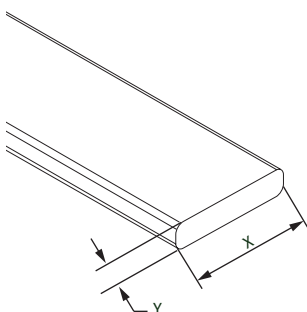

Kingsmill **Galvanised Steel Tape** is suitable for BS:EN 62305 internal foundation earthing rings.

CONDUCTOR SIZE (X x Y) (mm)	CSA (mm ²)	COIL SIZE (m)	WEIGHT (kg/m)	PART NO.
30 x 3.5	105	30	0.84	GST3035

Material: Galvanised Steel

Standard: BS:EN 62561-2