



**Horizontal parallel cable to horizontal rebar joint - CRE1**

A	B	Ⓢ°			
16	10 - 40	D	#045	HCD*	MDCRE116
25	10 - 40	D	#045	HCD*	MDCRE125
35	10 - 40	D	#045	HCD*	MDCRE135
50	10 - 40	D	#090	HCD*	MDCRE150
70	10 - 40	D	#090	HCD*	MDCRE170
95	10 - 40	D	#090	HCD*	MDCRE195
120	10 - 40	D	#090	HCD*	MDCRE1120
8 dia	10 - 40	D	#090	HCD*	MDCRE18S
10 dia	10 - 40	D	#090	HCD*	MDCRE110S

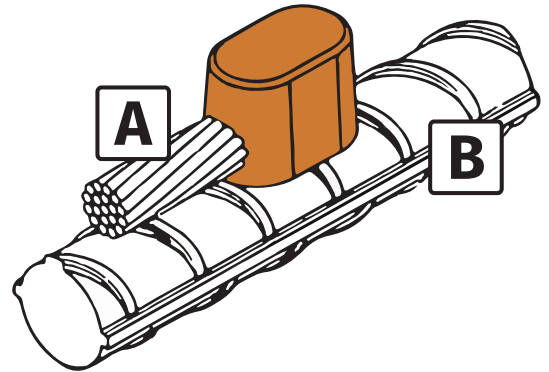

\*Requires chain clamp and butyl seal

16, 25, 35, 50, 70, 95 and 120 = stranded cable (mm<sup>2</sup>)

8 dia and 10 dia = solid copper/steel