

Introduction to exothermic welding	WELD:3
The KingsWeld process	WELD:4
Making a KingsWeld connection	WELD:4 - 5
The product (weld metals and moulds)	WELD:6
How to use this catalogue	WELD:7
Mould care guide and inspection	WELD:7
Selector charts	WELD:8 - 9
Mould types:	
- Cable to cable	WELD:10 - 15
- Cable to ground rod	WELD:16 - 18
- Cable to bar	WELD:19 - 21
- Bar to bar	WELD:22 - 24
- Cable to rebar	WELD:25 - 28
- Bar to ground rod	WELD:29 - 31
- Cable to surface	WELD:32 - 35
- Bar to surface	WELD:36 - 37
- Stud to surface	WELD:38
- Rail	WELD:39 - 40
Accessories	WELD:41
Handle Clamps	WELD:42
Earth Points	WELD:43
Legend	WELD:44



“Exothermic” is a chemical term used to describe a reaction that produces heat.

Exothermic welding, also known as “thermit welding” or “aluminothermic welding” is a welding process for permanently joining materials (usually copper conductors) that employs an exothermic reaction. The exothermic reaction requires no external heat or a power source. All that is required is a spark to initiate the reaction.

CABLE TO CABLE
pages
WELD:10 - 15

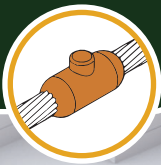

CABLE TO GROUND ROD
pages
WELD:16 - 18

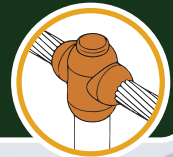

CABLE TO BAR
pages
WELD:19 - 21

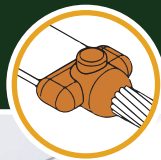

BAR TO BAR
pages
WELD:22 - 24



CABLE TO REBAR
pages
WELD:25 - 28

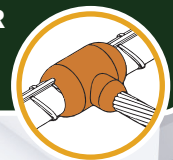

BAR TO GROUND ROD
pages
WELD:29 - 31

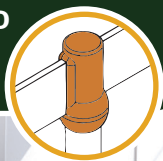

CABLE TO SURFACE
pages
WELD:32 - 35

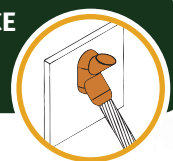

BAR TO SURFACE
pages
WELD:36 - 37



STUD TO SURFACE
page WELD:38

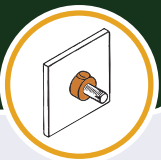

RAIL
pages
WELD:39 - 40

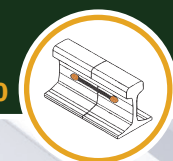

Introduction to exothermic welding

The exothermic reaction occurs between copper oxide and aluminium powder (contained within the weld metal) creating molten super-heated copper and an aluminium oxide slag. When an ignition spark comes into contact with the weld metal, it causes an exothermic reaction within the weld metal, melting and separating the metals. The aluminium rises to the top of the connection creating a slag leaving the molten copper to flow around the joint, creating the weld.

The KingsWeld exothermic connection is a permanent, maintenance-free weld that will not loosen overtime or deteriorate with age. The connections' current carrying capability is equal to or greater than that of the conductors being joined. In other words, there is no increase in resistance in an exothermically welded connection, unlike in most pressure type (bolt/crimp) connections.

Throughout the world, exothermic welding has been shown to be the best choice where safety, reliability, current carrying capacity and longevity are critical.

The advantages of exothermic welding

- 1 The current carrying capacity of the connection is greater than or equal to that of the conductor
- 2 Has a lower electrical resistance than a mechanical connection
- 3 Does not deteriorate with age
- 4 Does not loosen over time
- 5 Can withstand repeated high current surges without deterioration
- 6 Does not require an external power source
- 7 Used to weld copper, copper alloys, copper bonded steel, various steel alloys, including stainless steel
- 8 Quick and easy to install
- 9 Exceptional corrosion resistance due a very high copper content (97%+)
- 10 Fusion temperature is in excess of 2000°C forming a molecular bond

This adds up to a superior connection when compared to mechanical or pressure type (crimp) connectors.

The KingsWeld exothermic connection is the best choice, especially in safety critical environments where reliability, longevity and current carrying capacity are paramount.

KingsWeld online . . .

For additional moulds, troubleshooting guide, video tutorials and much more, visit www.kingsmillearthing.co.uk/kingsweld



The KingsWeld process

The KingsWeld exothermic process is a simple, self-contained, efficient way of welding copper-to-copper or copper-to-steel.

Each connection uses a KingsWeld weld metal which, when ignited, creates an exothermic reaction between copper oxide and aluminium powder.

The connections are produced inside a graphite mould, specifically designed to suit the size of conductors to be welded as well as the specific joint configuration.

Each connection requires a specific mould designed to suit the joint configuration and conductors being used. Each mould type requires a specific weld metal size. *This can be found in our mould selection charts detailed on pages WELD:8 - 9.*

Once the correct mould and weld metal have been selected, the process is simple and straightforward.

The conductors are positioned in the graphite mould. A steel retaining disc is then inserted into the mould before any weld metal is added. Only after the disc is in place and properly seated can the main weld metal (under the green cap) be poured into the reaction crucible. The ignition temperature of the main weld metal is approximately 1000°C. This is difficult to achieve and so we use a starter powder to start the exothermic reaction, this is contained under the red cap. The starter powder is similar to the main weld metal, but finer, allowing ignition at around 450°C (through using the spark from a flint ignitor).

The resultant exothermic reaction produces high temperature molten copper (in excess of 2000°C) and aluminium slag.

The molten copper melts the steel retaining disc and flows down the tap hole into the joint cavity. In doing so, the molten copper melts and welds the conductors into a solid homogenous joint.

The whole process takes no more than a few seconds.

The aluminium oxide produced stays on top of the joint and is easily removed.

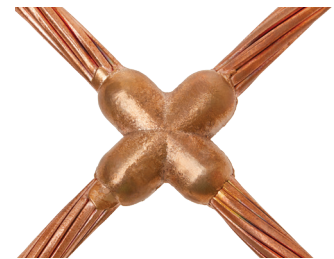

Making a KingsWeld connection

Items required to make a connection:

- KingsWeld mould
- Handle clamp
- Weld metal
- Flint gun

Before making a KingsWeld connection:

- Always wear proper clothing, gloves and safety glasses when exothermic welding.
- Read the general safety instructions and the positioning of conductors sheet supplied with each KingsWeld mould to familiarise yourself with the procedure you are going to perform.
- Make sure the conductors that are to be welded are dry, dirt-free and clean.
- Use the wire brush to clean the conductor surfaces being placed inside the mould - the cleaner the surface the better the connection will be.
- Attach the handle clamp to the KingsWeld mould and check it will open & close freely.
- Make sure that the KingsWeld mould is dry and moisture free. The best way to do this is by pre-heating the mould with a blow torch or by making a test connection.

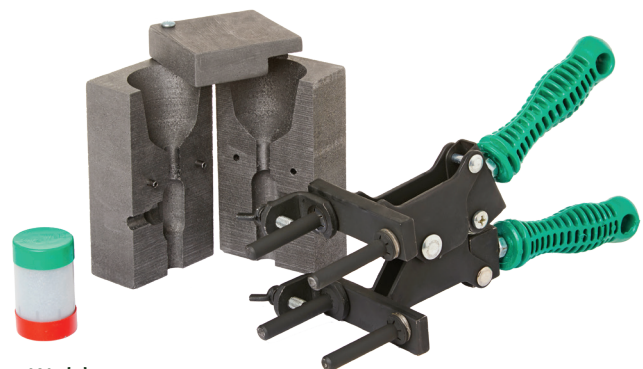

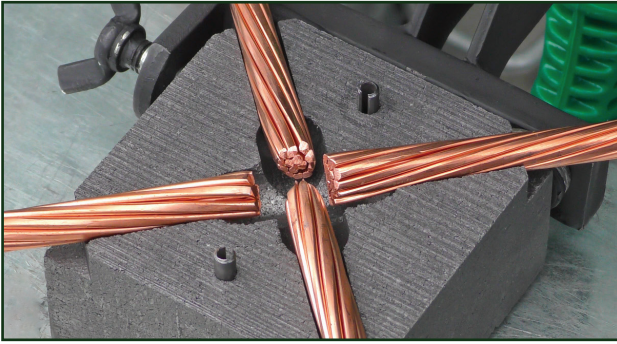

- 1 Position cleaned conductors in the mould**
 Make sure the mould is dry & moisture-free by pre-heating or making a test connection.



- 2 Place the metal disc in the bottom of the mould crucible**
 Discs are supplied with the weld metal.



- 3 Pour weld metal into the mould crucible**
 Weld metal is under the green cap.
 Pour all weld metal into the crucible.



- 4 Add starting powder to the weld metal**
 Starting powder is under the red cap.
 Pour on top of the weld metal. Add a small amount of starting powder to the lip of the mould - to aid ignition - and close the lid.

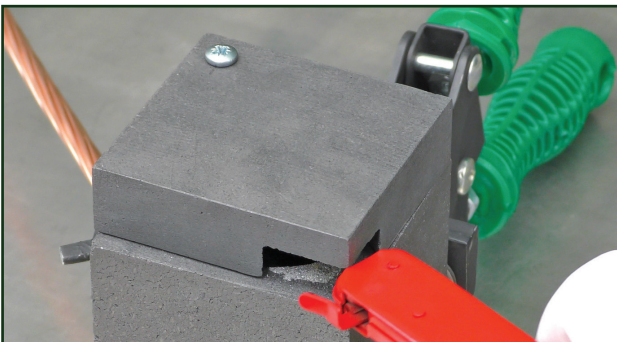

- 5 Use flint gun to ignite starting powder**
 Pull flint gun away as soon as trigger is pulled to keep from fouling flint gun.
CAUTION: do not place any exposed body part directly over lid or in front of opening.

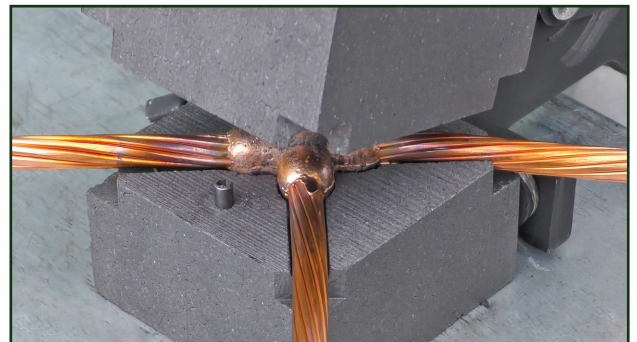

- 6 After approximately 20 seconds open the mould with the handle clamp**
 Knock off slag with the mould cleaning brush handle and clean the mould thoroughly, including the crucible and lid.

The product

A KingsWeld weld metal consists of copper oxide, aluminium and flux in a granular (powder) form.

Each weld metal is packed into a plastic container. Different connections require differing weld metal sizes and so each container is marked with the weld metal size (grams).

These sizes are detailed in the table (right), which also provides our standard packaging information.

DESCRIPTION	INNER PACK QTY.	PACK WEIGHT (kg)	PART NO.
Weld metal 15	20	0.60	#015
Weld metal 25	20	0.80	#025
Weld metal 32	20	0.90	#032
Weld metal 45	20	1.21	#045
Weld metal 65	10	0.88	#065
Weld metal 90	10	1.22	#090
Weld metal 115	10	1.58	#115
Weld metal 150	10	1.86	#150
Weld metal 200	10	2.06	#200
Weld metal 250	10	3.04	#250

Weld metals

The weld metals are packed into plastic inner cartons, each of which contains metal discs, a moisture absorbing sachet and a box label, clearly identifying size, quantity and batch information.

The weld metal container has two compartments. The main weld metal is under the green cap and the starter powder is under the red cap.



KingsWeld moulds

The KingsWeld exothermic mould is manufactured from high quality graphite. This lends itself to easy machining, as well as being able to withstand the high thermal and mechanical shocks produced during the exothermic welding process. Heat obtained in such reactions is in excess of 2000°C.

Our moulds are designed to have an average lifetime of 50 to 60 connections. But, if treated with care, it is possible to obtain a significantly longer life.

Graphite is both brittle and soft, therefore it is important that the operator takes care whilst handling the product.

Worn-out or damaged moulds should not be used.

Each mould has a nameplate, detailing the connection type, part code and the correct weld metal size to be used.



The KingsWeld range of moulds can be seen on pages WELD:8 - 9. If you do not see the connection, configuration or size of conductor that you require, please contact our sales office who will be pleased to assist you.

How to use this catalogue







The KingsWeld catalogue lists the most commonly used exothermic connections. However, if you cannot find the one that you are looking for, please contact our sales office who will be pleased to assist.

Select the mould connection configuration required using charts on pages WELD:8 - 9. Go to the pages highlighted under that connection type and refer to the connection table. Select the conductor sizes to be joined.

By following the line across you will find:

- Mould price key
- Weld metal size
- Handle clamp size
- Accessories
- Part number

Now, all you need to add is a tool kit and you are set to go.

A B						
Conductor size	Price key	Weld metal	Clamp	Mould	Sleeve	Hammer die

Product table icons, above, are explained in detail on page WELD:41 - Legend.

Mould care guide

KingsWeld moulds are manufactured from high quality graphite which, by nature, is soft and needs to be handled with care in order to get the maximum lifetime.

- Always clean the mould after every weld
- Only use KingsWeld cleaning equipment (soft brush) to clean the mould
- Keep the mould dry and away from moisture
- Do not hit or drop the mould
- When not in use, keep the mould in its packaging for protection
- Try not to hit the edges of the mould with the conductors to be connected
- Never use a wire brush to clean the mould
- Always use the correct weld metal size, tools and handle clamps

Mould inspection

- Handle the mould with care.
- Mould must be dry with fixed lid.
- Identification plate must be attached.
- Mould faces must be smooth, so they seal properly.
- Mould steel disc seat must not show signs of wear, chips or gouges (steel disc must seal the hole properly to prevent weld metal entering the weld cavity prior to welding).
- Tap hole must be well defined.
- Weld cavity must not show signs of wear, chips or gouges (conductors must have a 3mm gap between them prior to welding, fit snugly and not be loose in the mould).

Regular checks help keep moulds in good condition.

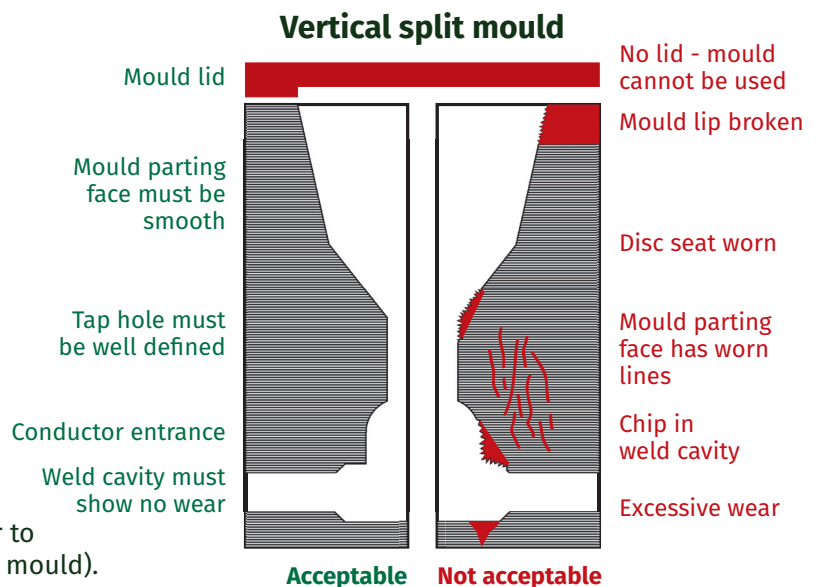

Selector charts

Cable to cable

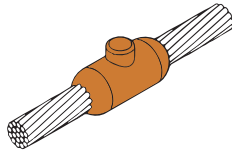

CC1 - WELD:10

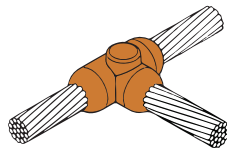

CC2 - WELD:11

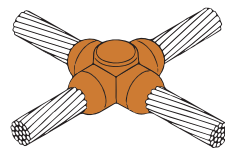

CC4 - WELD:12

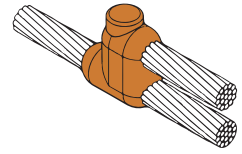

CC6 - WELD:13

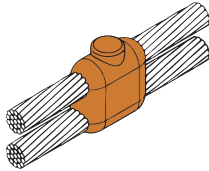

CC7 - WELD:14

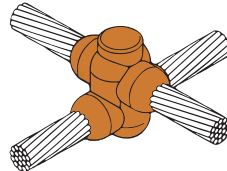

CC11 - WELD:15

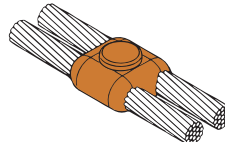

CC14 - WELD:15

Cable to ground rod

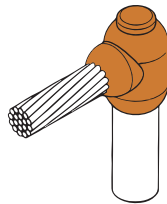

CR1 - WELD:16

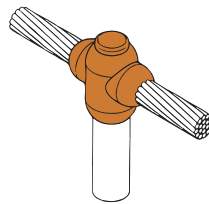

CR2 - WELD:17

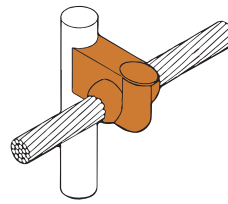

CR3 - WELD:18

Cable to bar

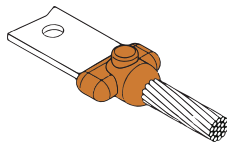

CB1 - WELD:19

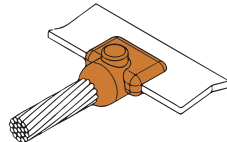

CB4 - WELD:20

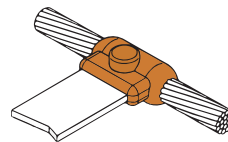

CB5 - WELD:21

Bar to bar

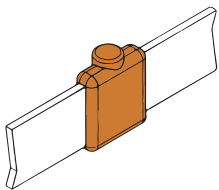

BB1 - WELD:22

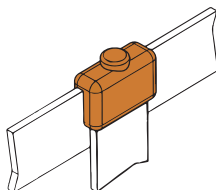

BB3 - WELD:22

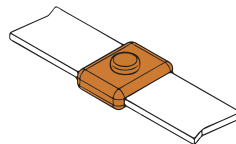

BB7 - WELD:23

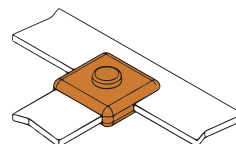

BB14 - WELD:23

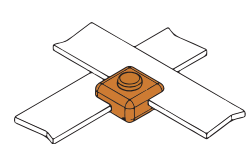

BB41 - WELD:24

Cable to rebar

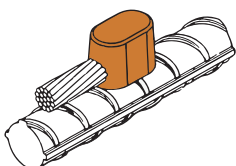

CRE1 - WELD:25

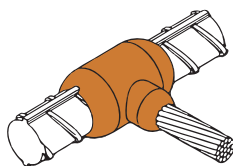

CRE2 - WELD:26

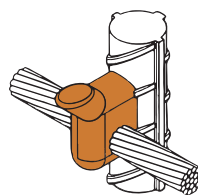

CRE3 - WELD:27

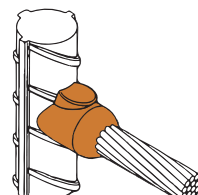

CRE6 - WELD:27

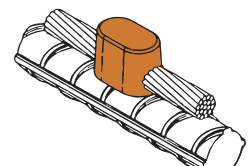

CRE17 - WELD:28

Selector charts

Bar to ground rod

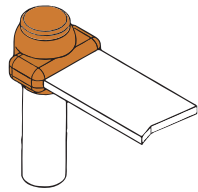

BR1 - WELD:29

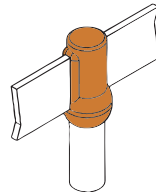

BR2 - WELD:30

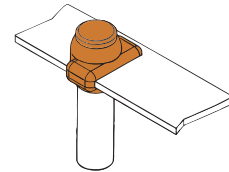

BR7 - WELD:31

Cable to surface

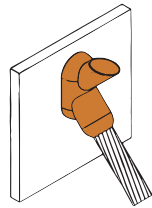

CS3 - WELD:32

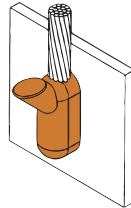

CS7 - WELD:32

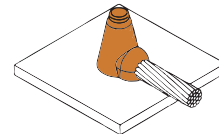

CS8 - WELD:33

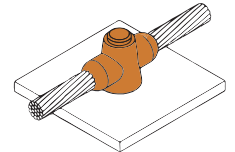

CS9 - WELD:33

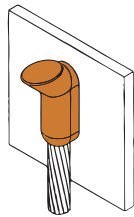

CS25 - WELD:34

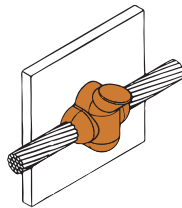

CS27 - WELD:34

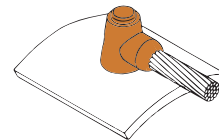

CS32 - WELD:35

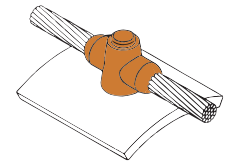

CS34 - WELD:35

Bar to surface

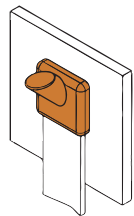

BS1 - WELD:36

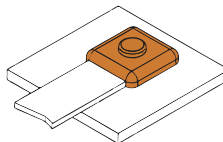

BS2 - WELD:36

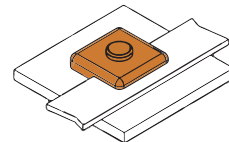

BS3 - WELD:37

Stud to surface

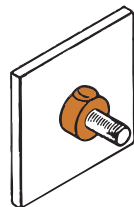

RS1 - WELD:38

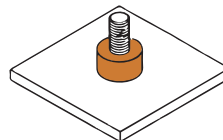

RS2 - WELD:38

Rail

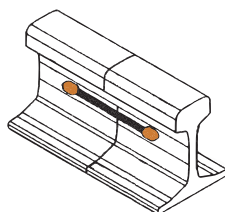

R4 - WELD:39

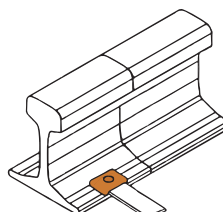

R6 - WELD:39

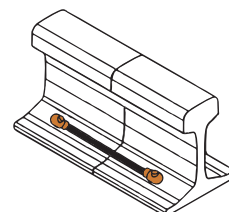

R10 - WELD:40

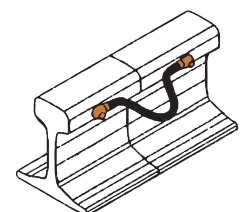

R12 - WELD:40

Horizontal end to end joint - CC1

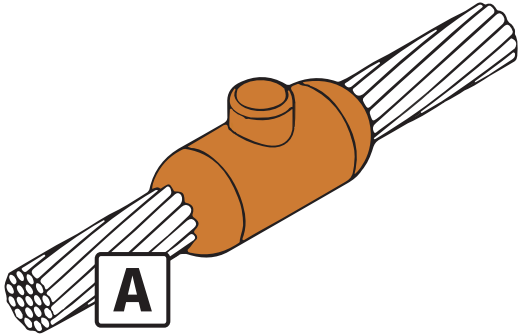

A	°			
16	D	#032	HCD	MDCC116
25	D	#032	HCD	MDCC125
35	D	#032	HCD	MDCC135
50	D	#045	HCD	MDCC150
70	D	#065	HCD	MDCC170
95	D	#090	HCD	MDCC195
120	D	#115	HCD	MDCC1120
150	D	#115	HCD	MDCC1150
185	D	#150	HCD	MDCC1185
240	D	#200	HCD	MDCC1240
300	D	#250	HCD	MDCC1300
400	E	2 x #150	HCE	MECC1400
8 dia	D	#045	HCD	MDCC18S
10 dia	D	#065	HCD	MDCC110S

16, 25, 35, 50, 70, 95, 120, 150, 185, 240, 300 and 400
= stranded cable (mm²)

8 dia and 10 dia = solid copper/steel

Horizontal cable run to horizontal cable tap tee joint - CC2

A	B	Sp	Welding Rod	Welding Method	Welding Product
16	16	D	#045	HCD	MDCC21616
25	25	D	#045	HCD	MDCC22525
35	25	D	#045	HCD	MDCC23525
35	35	D	#045	HCD	MDCC23535
50	25	D	#065	HCD	MDCC25025
50	35	D	#065	HCD	MDCC25035
50	50	D	#090	HCD	MDCC25050
70	25	D	#065	HCD	MDCC27025
70	35	D	#065	HCD	MDCC27035
70	50	D	#090	HCD	MDCC27050
70	70	D	#090	HCD	MDCC27070
95	35	D	#090	HCD	MDCC29535
95	50	D	#090	HCD	MDCC29550
95	70	D	#090	HCD	MDCC29570
95	95	D	#115	HCD	MDCC29595
95	240	D	#150	HCD	MDCC295240
120	50	D	#090	HCD	MDCC212050
120	70	D	#090	HCD	MDCC212070
120	95	D	#150	HCD	MDCC212095
120	120	D	#150	HCD	MDCC2120120
150	70	D	#090	HCD	MDCC215070
150	95	D	#150	HCD	MDCC215095
150	120	D	#150	HCD	MDCC2150120
150	150	D	#200	HCD	MDCC2150150
185	95	D	#150	HCD	MDCC218590
185	120	D	#200	HCD	MDCC2185120
185	150	D	#200	HCD	MDCC2185150
185	185	D	#200	HCD	MDCC2185185
240	120	D	#200	HCD	MDCC2240120
240	150	D	#200	HCD	MDCC2240150
240	185	D	#200	HCD	MDCC2240185
240	240	E	2 x #150	HCE	MECC2240240
300	35	D	#115	HCD	MDCC230035
300	70	D	#200	HCD	MDCC230070
300	120	D	#200	HCD	MDCC2300120
300	150	D	#200	HCD	MDCC2300150
300	185	D	#250	HCD	MDCC2300185
300	240	E	2 x #200	HCE	MECC2300240
300	300	E	2 x #200	HCE	MECC2300300
400	240	E	2 x #250	HCE	MECC2400240
400	400	E	2 x #250	HCE	MECC2400400
8 dia	8 dia	D	#065	HCD	MDCC28S8S
10 dia	10 dia	D	#090	HCD	MDCC210S10S

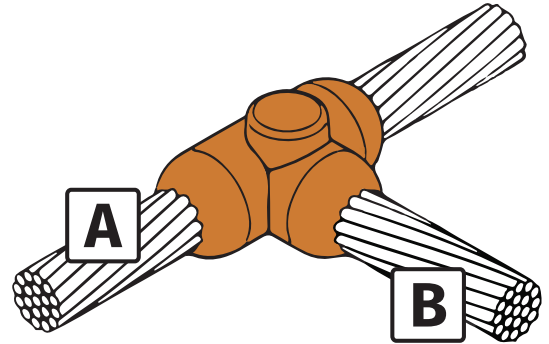



16, 25, 35, 50, 70, 95, 120, 150, 185, 240, 300 and 400
= stranded cable (mm²)

8 dia and 10 dia = solid copper/steel

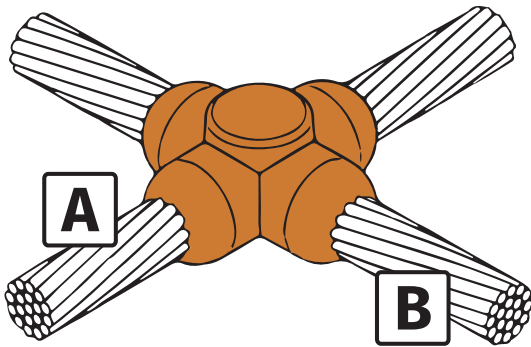
Horizontal to horizontal cable cross joint - CC4



A	B	°			
16	16	D	#045	HCD	MDCC41616
25	25	D	#045	HCD	MDCC42525
35	25	D	#065	HCD	MDCC43525
35	35	D	#065	HCD	MDCC43535
50	25	D	#090	HCD	MDCC45025
50	35	D	#090	HCD	MDCC45035
50	50	D	#090	HCD	MDCC45050
70	25	D	#115	HCD	MDCC47025
70	35	D	#115	HCD	MDCC47035
70	50	D	#115	HCD	MDCC47050
70	70	D	#115	HCD	MDCC47070
95	35	D	#115	HCD	MDCC49535
95	50	D	#115	HCD	MDCC49550
95	70	D	#150	HCD	MDCC49570
95	95	D	#150	HCD	MDCC49595
120	50	D	#150	HCD	MDCC412050
120	70	D	#150	HCD	MDCC412070
120	95	D	#200	HCD	MDCC412095
120	120	D	#200	HCD	MDCC4120120
150	70	D	#150	HCD	MDCC415070
150	95	D	#200	HCD	MDCC415095
150	120	D	#250	HCD	MDCC4150120
150	150	D	#250	HCD	MDCC4150150
185	70	D	#200	HCD	MDCC418570
185	95	D	#200	HCD	MDCC418595
185	120	D	#250	HCD	MDCC4185120
185	150	D	#250	HCD	MDCC4185150
185	185	E	2 x #150	HCE	MECC4185185
240	120	E	2 x #150	HCE	MECC4240120
240	150	E	2 x #200	HCE	MECC4240150
240	185	E	2 x #200	HCE	MECC4240185
240	240	E	2 x #250	HCE	MECC4240240
300	95	E	2 x #200	HCE	MECC430095
300	120	E	2 x #200	HCE	MECC4300120
300	150	E	2 x #250	HCE	MECC4300150
300	185	E	2 x #250	HCE	MECC4300185
300	240	E	3 x #200	HCE	MECC4300240
300	300	E	3 x #200	HCE	MECC4300300
8 dia	8 dia	D	#090	HCD	MDCC48S8S
10 dia	10 dia	D	#115	HCD	MDCC410S10S

16, 25, 35, 50, 70, 95, 120, 150, 185, 240 and 300 = stranded cable (mm²)

8 dia and 10 dia = solid copper/steel

Three way cable joint - CC6

A	B	°	☐	✂	☐
16	16	D	#045	HCD	MDCC61616
25	25	D	#045	HCD	MDCC62525
35	25	D	#065	HCD	MDCC63525
35	35	D	#065	HCD	MDCC63535
50	25	D	#065	HCD	MDCC65025
50	35	D	#065	HCD	MDCC65035
50	50	D	#090	HCD	MDCC65050
70	25	D	#090	HCD	MDCC67025
70	35	D	#090	HCD	MDCC67035
70	50	D	#115	HCD	MDCC67050
70	70	D	#115	HCD	MDCC67070
95	35	D	#115	HCD	MDCC69535
95	50	D	#115	HCD	MDCC69550
95	70	D	#115	HCD	MDCC69570
95	95	D	#150	HCD	MDCC69595
120	50	D	#150	HCD	MDCC612050
120	70	D	#150	HCD	MDCC612070
120	95	D	#200	HCD	MDCC612095
120	120	D	#200	HCD	MDCC6120120

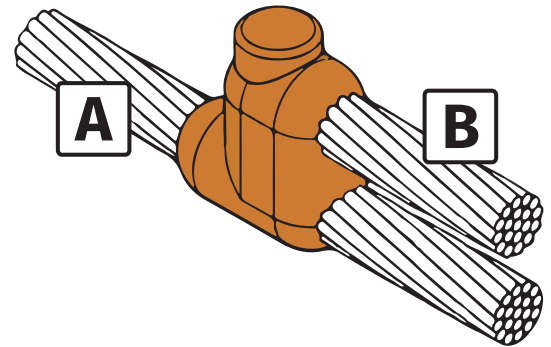

16, 25, 35, 50, 70, 95 and 120 = stranded cable (mm²)

Vertical parallel cable joint - CC7

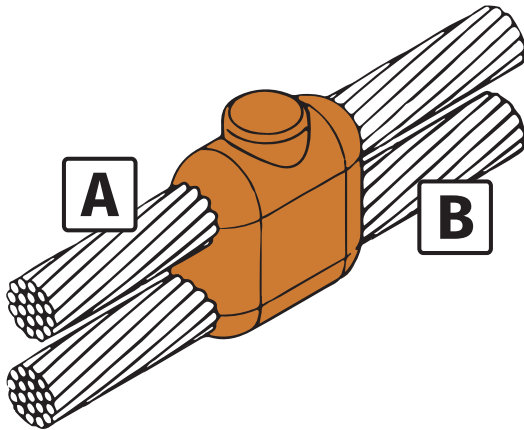

A	B	°	Icon 1	Icon 2	Icon 3
16	16	D	#045	HCD	MDCC71616
25	25	D	#045	HCD	MDCC72525
35	25	D	#065	HCD	MDCC73525
35	35	D	#065	HCD	MDCC73535
50	25	D	#065	HCD	MDCC75025
50	35	D	#065	HCD	MDCC75035
50	50	D	#090	HCD	MDCC75050
70	25	D	#090	HCD	MDCC77025
70	35	D	#090	HCD	MDCC77035
70	50	D	#115	HCD	MDCC77050
70	70	D	#115	HCD	MDCC77070
95	35	D	#115	HCD	MDCC79535
95	50	D	#115	HCD	MDCC79550
95	70	D	#115	HCD	MDCC79570
95	95	D	#150	HCD	MDCC79595
120	50	D	#150	HCD	MDCC712050
120	70	D	#150	HCD	MDCC712070
120	120	D	#200	HCD	MDCC7120120
120	150	D	#200	HCD	MDCC7120150
150	70	D	#150	HCD	MDCC715070
150	95	D	#200	HCD	MDCC715095
150	120	D	#250	HCD	MDCC7150120
150	150	E	2 x #150	HCE	MECC7150150
185	95	D	#200	HCD	MDCC718595
185	120	D	#250	HCD	MDCC7185120
185	150	E	2 x #150	HCE	MECC7185150
185	185	E	2 x #150	HCE	MECC7185185
240	120	D	#250	HCD	MDCC7240120
240	150	E	2 x #150	HCE	MECC7240150
240	185	E	2 x #150	HCE	MECC7240185
240	240	E	2 x #200	HCE	MECC7240240
300	150	E	2 x #150	HCE	MECC7300150
300	185	E	2 x #200	HCE	MECC7300185
300	240	E	2 x #250	HCE	MECC7300240
300	300	E	2 x #250	HCE	MECC7300300
8 dia	8 dia	D	#090	HCD	MDCC78S8S
10 dia	10 dia	D	#115	HCD	MDCC710S10S

16, 25, 35, 50, 70, 95, 120, 150, 185, 240 and 300 = stranded cable (mm²)

8 dia and 10 dia = solid copper/steel

Crossover cable joint - CC11

A	B	Sp	Icon 1	Icon 2	Icon 3
50	50	D	#150	HCD	MDCC115050
70	70	D	#200	HCD	MDCC117070
95	95	D	#250	HCD	MDCC119595
120	120	E	2 x #150	HCE	MECC11120120
150	150	E	2 x #200	HCE	MECC11150150
185	185	F	2 x #250	HCE	MFCC11185185
240	240	F	3 x #250	HCE	MFCC11240240
300	300	F	3 x #250	HCE	MFCC11300300
8 dia	8 dia	D	#150	HCD	MDCC118S8S
10 dia	10 dia	D	#150	HCD	MDCC1110S10S

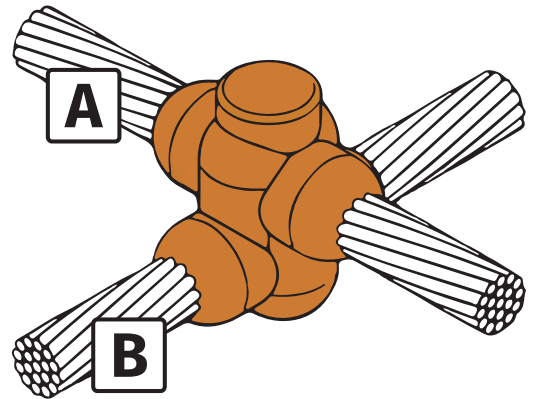

50, 70, 95, 120, 150, 185, 240 and 300 = stranded cable (mm²)

8 dia and 10 dia = solid copper/steel

Horizontal parallel cable joint - CC14

A	B	Sp	Icon 1	Icon 2	Icon 3
16	16	D	#045	HCD	MDCC141616
25	25	D	#045	HCD	MDCC142525
35	25	D	#065	HCD	MDCC143525
35	35	D	#065	HCD	MDCC143535
50	25	D	#090	HCD	MDCC145925
50	35	D	#090	HCD	MDCC145035
50	50	D	#090	HCD	MDCC145050
70	25	D	#090	HCD	MDCC147025
70	35	D	#090	HCD	MDCC147035
70	50	D	#115	HCD	MDCC147050
70	70	D	#115	HCD	MDCC147070
95	35	D	#115	HCD	MDCC149535
95	50	D	#150	HCD	MDCC149550
95	70	D	#150	HCD	MDCC149570
95	95	D	#150	HCD	MDCC149595
120	50	D	#150	HCD	MDCC1412050
120	70	D	#200	HCD	MDCC1412070
120	95	D	#200	HCD	MDCC1412095
120	120	D	#200	HCD	MDCC14120120
8 dia	8 dia	D	#090	HCD	MDCC148S8S
10 dia	10 dia	D	#115	HCD	MDCC1410S10S

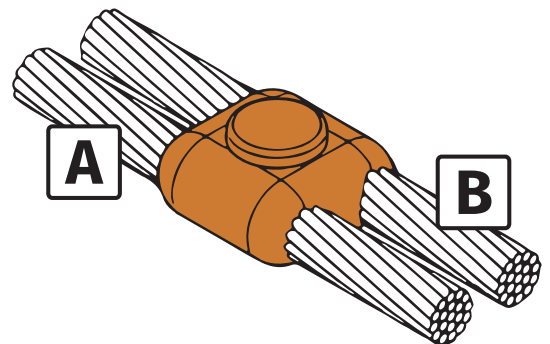

16, 25, 35, 50, 70, 95 and 120 = stranded cable (mm²)

8 dia and 10 dia = solid copper/steel

Horizontal cable terminal to ground rod joint - CR1

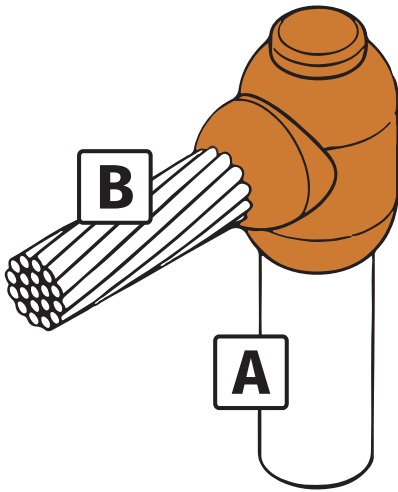

A	B	Ⓢ	Ⓢ	Ⓢ	Ⓢ
12.7	16	D	#065	HCD	MDCR112.716
12.7	25	D	#065	HCD	MDCR112.725
12.7	35	D	#065	HCD	MDCR112.735
12.7	50	D	#065	HCD	MDCR112.750
12.7	70	D	#090	HCD	MDCR112.770
12.7	95	D	#090	HCD	MDCR112.795
12.7	120	D	#090	HCD	MDCR112.7120
12.7	8 dia	D	#065	HCD	MDCR112.78S
12.7	10 dia	D	#090	HCD	MDCR112.710S
14.2	16	D	#065	HCD	MDCR114.216
14.2	25	D	#065	HCD	MDCR114.225
14.2	35	D	#065	HCD	MDCR114.235
14.2	50	D	#090	HCD	MDCR114.250
14.2	70	D	#090	HCD	MDCR114.270
14.2	95	D	#090	HCD	MDCR114.295
14.2	120	D	#090	HCD	MDCR114.2120
14.2	150	D	#115	HCD	MDCR114.2150
14.2	185	D	#115	HCD	MDCR114.2185
14.2	240	D	#150	HCD	MDCR114.2240
14.2	8 dia	D	#090	HCD	MDCR114.28S
14.2	10 dia	D	#115	HCD	MDCR114.210S
17.2	16	D	#065	HCD	MDCR117.216
17.2	25	D	#065	HCD	MDCR117.225
17.2	35	D	#065	HCD	MDCR117.235
17.2	50	D	#090	HCD	MDCR117.250
17.2	70	D	#090	HCD	MDCR117.270
17.2	95	D	#090	HCD	MDCR117.295
17.2	120	D	#090	HCD	MDCR117.2120
17.2	150	D	#115	HCD	MDCR117.2150
17.2	185	D	#115	HCD	MDCR117.2185
17.2	240	D	#150	HCD	MDCR117.2240
17.2	300	D	#200	HCD	MDCR117.2300
16	16	D	#65	HCD	MDCR11616
16	25	D	#65	HCD	MDCR11625
16	35	D	#65	HCD	MDCR11635
16	50	D	#90	HCD	MDCR11650
16	70	D	#90	HCD	MDCR11670
16	95	D	#90	HCD	MDCR11695
16	120	D	#90	HCD	MDCR116120
16	150	D	#115	HCD	MDCR116150
16	185	D	#115	HCD	MDCR116185
16	240	D	#150	HCD	MDCR116240
16	300	D	#200	HCD	MDCR116300
20	16	D	#90	HCD	MDCR12016
20	25	D	#90	HCD	MDCR12025
20	35	D	#90	HCD	MDCR12035
20	50	D	#90	HCD	MDCR12050
20	70	D	#90	HCD	MDCR12070
20	95	D	#90	HCD	MDCR12095
20	120	D	#115	HCD	MDCR120120
20	150	D	#115	HCD	MDCR120150
20	185	D	#115	HCD	MDCR120185
20	240	D	#200	HCD	MDCR120240
20	300	D	#200	HCD	MDCR120300

A 12.7, 14.2 and 17.2 = copperbond
16 and 20 = solid copper/steel

B 16, 25, 35, 50, 70, 95, 120, 150, 185, 240, 300 and 400 = stranded cable (mm²)
8 dia and 10 dia = solid copper/steel

Horizontal cable to ground rod tee joint - CR2

A	B	So			
12.7	16	D	#090	HCD	MDCR212.716
12.7	25	D	#090	HCD	MDCR212.725
12.7	35	D	#090	HCD	MDCR212.735
12.7	50	D	#090	HCD	MDCR212.750
12.7	70	D	#090	HCD	MDCR212.770
12.7	95	D	#115	HCD	MDCR212.795
12.7	8 dia	D	#065	HCD	MDCR212.78S
12.7	10 dia	D	#090	HCD	MDCR212.710S
14.2	16	D	#090	HCD	MDCR214.216
14.2	25	D	#090	HCD	MDCR214.225
14.2	35	D	#090	HCD	MDCR214.235
14.2	50	D	#090	HCD	MDCR214.250
14.2	70	D	#115	HCD	MDCR214.270
14.2	95	D	#115	HCD	MDCR214.295
14.2	120	D	#150	HCD	MDCR214.2120
14.2	150	D	#200	HCD	MDCR214.2150
14.2	185	D	#200	HCD	MDCR214.2185
14.2	240	D	#250	HCD	MDCR214.2240
14.2	8 dia	D	#090	HCD	MDCR214.28S
14.2	10 dia	D	#115	HCD	MDCR214.210S
17.2	16	D	#090	HCD	MDCR217.216
17.2	25	D	#090	HCD	MDCR217.225
17.2	35	D	#090	HCD	MDCR217.235
17.2	50	D	#115	HCD	MDCR217.250
17.2	70	D	#115	HCD	MDCR217.270
17.2	95	D	#115	HCD	MDCR217.295
17.2	120	D	#150	HCD	MDCR217.2120
17.2	150	D	#200	HCD	MDCR217.2150
17.2	185	D	#200	HCD	MDCR217.2185
17.2	240	D	#250	HCD	MDCR217.2240
17.2	300	E	2 x #150	HCE	MECR217.2300
16	16	D	#90	HCD	MDCR21616
16	25	D	#90	HCD	MDCR21625
16	35	D	#90	HCD	MDCR21635
16	50	D	#90	HCD	MDCR21650
16	70	D	#115	HCD	MDCR21670
16	95	D	#115	HCD	MDCR21695
16	120	D	#150	HCD	MDCR216120
16	150	D	#200	HCD	MDCR216150
16	185	D	#200	HCD	MDCR216185
16	240	D	#250	HCD	MDCR216240
16	300	D	#250	HCD	MDCR216300
16	400	E	2 x #200	HCE	MECR216400
20	16	D	#90	HCD	MDCR22016
20	25	D	#90	HCD	MDCR22025
20	35	D	#90	HCD	MDCR22035
20	50	D	#150	HCD	MDCR22050
20	70	D	#150	HCD	MDCR22070
20	95	D	#115	HCD	MDCR22095
20	120	D	#200	HCD	MDCR220120
20	240	D	#250	HCD	MDCR220240
20	300	D	2 x #150	HCD	MDCR220300
20	400	E	2 x #200	HCE	MECR220400

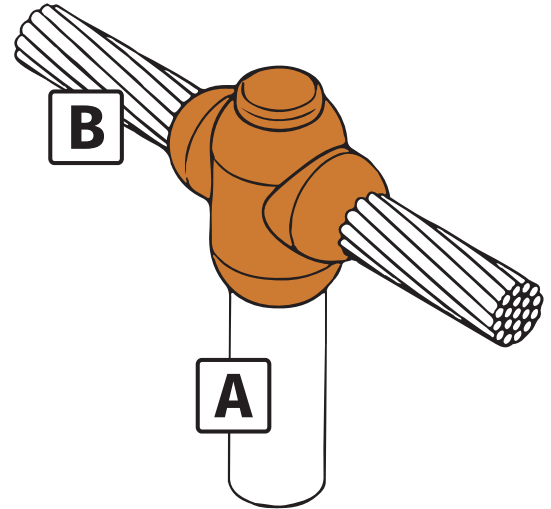

A 12.7, 14.2 and 17.2 = copperbond
16 and 20 = solid copper/steel

B 16, 25, 35, 50, 70, 95, 120, 150, 185, 240, 300 and 400
= stranded cable (mm²)
8 dia and 10 dia = solid copper/steel

Horizontal thru cable to ground rod cross joint - CR3

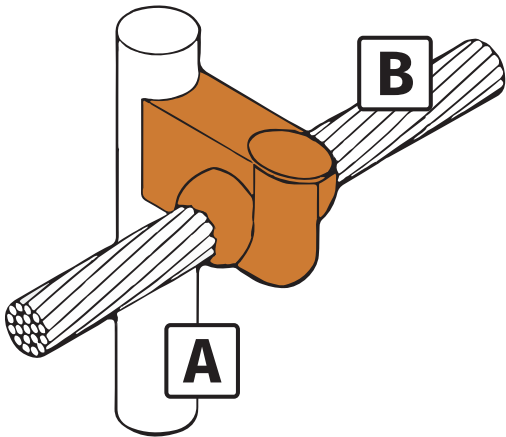

A	B	°	Icon 1	Icon 2	Icon 3
12.7	16	F	#090	HCE	MFCR312.716
12.7	25	F	#090	HCE	MFCR312.725
12.7	35	F	#090	HCE	MFCR312.735
12.7	50	F	#115	HCE	MFCR312.750
12.7	70	F	#115	HCE	MFCR312.770
12.7	95	F	#115	HCE	MFCR312.795
12.7	8 dia	F	#115	HCE	MFCR312.78S
14.2	16	F	#090	HCE	MFCR314.216
14.2	25	F	#090	HCE	MFCR314.225
14.2	35	F	#090	HCE	MFCR314.235
14.2	50	F	#115	HCE	MFCR314.250
14.2	70	F	#115	HCE	MFCR314.270
14.2	95	F	#115	HCE	MFCR314.295
14.2	8 dia	F	#115	HCE	MFCR314.28S
14.2	120	F	#150	HCE	MFCR314.2120
14.2	150	F	#200	HCE	MFCR314.2150
14.2	185	F	#250	HCE	MFCR314.2185
14.2	240	F	2 x #200	HCE	MFCR314.2240
14.2	300	F	2 x #250	HCE	MFCR314.2300
17.2	16	F	#90	HCE	MFCR317.216
17.2	25	F	#90	HCE	MFCR317.225
17.2	35	F	#90	HCE	MFCR317.235
17.2	50	F	#115	HCE	MFCR317.250
17.2	70	F	#150	HCE	MFCR314.270
17.2	95	F	#150	HCE	MFCR317.295
17.2	120	F	#200	HCE	MFCR317.2120
17.2	150	F	#250	HCE	MFCR317.2150
17.2	185	F	2 x #200	HCE	MFCR317.2185
17.2	240	F	2 x #200	HCE	MFCR317.2240
17.2	300	F	3 x #200	HCE	MFCR317.2300
16	50	F	#115	HCE	MFCR31650
16	70	F	#115	HCE	MFCR31670
20	50	F	#115	HCE	MFCR32050
20	70	F	#150	HCE	MFCR32070
20	95	F	#150	HCE	MFCR32095
20	120	F	#200	HCE	MFCR320120
20	300	F	3 X #200	HCE	MFCR320300

A 12.7, 14.2 and 17.2 = copperbond / 16 and 20 = solid copper/steel

B 16, 25, 35, 50, 70, 95, 120, 150, 185, 240 and 300 = stranded cable (mm²)
8 dia = solid copper/steel

Horizontal cable to horizontal bar joint - CB1

A	B	Sp			
10	20 x 2	D	#032	HCD	MDCB110202
16	20 x 2	D	#032	HCD	MDCB116202
16	20 x 3	D	#045	HCD	MDCB116203
16	25 x 3	D	#045	HCD	MDCB116253
25	20 x 3	D	#045	HCD	MDCB125203
25	25 x 3	D	#045	HCD	MDCB125253
35	20 x 3	D	#045	HCD	MDCB135203
35	25 x 3	D	#045	HCD	MDCB135253
50	20 x 3	D	#045	HCD	MDCB150203
50	25 x 2	D	#045	HCD	MDCB150252
50	25 x 3	D	#065	HCD	MDCB150253
70	25 x 3	D	#065	HCD	MDCB170253
70	25 x 4	D	#065	HCD	MDCB170254
70	25 x 5	D	#065	HCD	MDCB170255
70	25 x 6	D	#065	HCD	MDCB170256
95	25 x 4	D	#090	HCD	MDCB195254
95	25 x 5	D	#090	HCD	MDCB195255
95	25 x 6	D	#090	HCD	MDCB195256
120	25 x 5	D	#090	HCD	MDCB1120255
120	25 x 6	D	#090	HCD	MDCB1120256
120	30 x 5	D	#115	HCD	MDCB1120305
150	25 x 6	D	#115	HCD	MDCB1150256
150	30 x 5	D	#115	HCD	MDCB1150305
150	40 x 5	D	#150	HCD	MDCB1150405
185	31 x 6	D	#150	HCD	MDCB1185316
185	40 x 5	D	#150	HCD	MDCB1185405
185	50 x 5	E	#200	HCE	MECB1185505
240	50 x 5	E	#200	HCE	MECB1240505
240	50 x 6	E	2 x #150	HCE	MECB1240506
300	50 x 6	E	2 x #150	HCE	MECB1300506
300	50 x 8	D	2 x #200	HCD	MDCB1300508
8 dia	20 x 3	D	#045	HCD	MDCB18S203
8 dia	25 x 2	D	#045	HCD	MDCB18S252
8 dia	25 x 3	D	#065	HCD	MDCB18S253
10 dia	25 x 3	D	#065	HCD	MDCB110S253
10 dia	25 x 4	D	#065	HCD	MDCB110S254
10 dia	25 x 6	D	#065	HCD	MDCB110S256

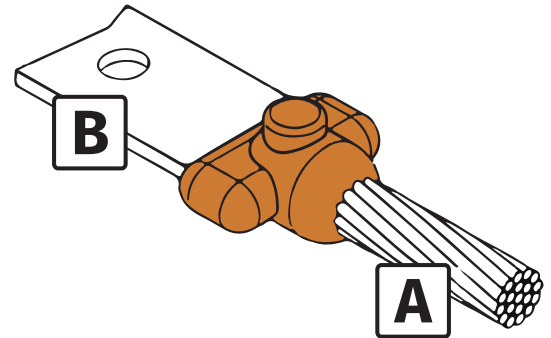

10, 16, 25, 35, 50, 70, 95, 120, 150, 185, 240 and 300 = stranded cable (mm²)

8 dia and 10 dia = solid copper/steel

Horizontal cable run to horizontal bar tee joint - CB4

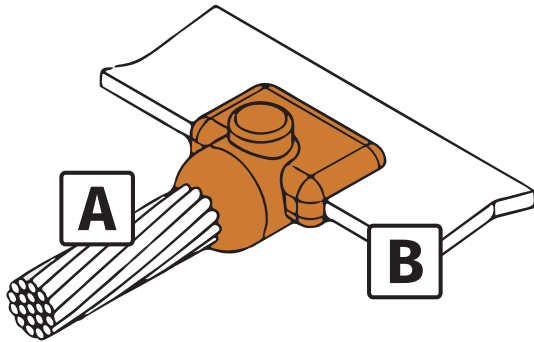

A	B	Ⓢ	🗑️	✂️	📦
10	20 x 2	D	#032	HCD	MDCB410202
16	20 x 2	D	#032	HCD	MDCB416202
16	20 x 3	D	#045	HCD	MDCB416203
16	25 x 3	D	#045	HCD	MDCB416253
16	40 x 6	D	#090	HCD	MDCB416406
16	50 x 6	D	#090	HCD	MDCB416506
25	20 x 2	D	#032	HCD	MDCB425202
25	20 x 3	D	#032	HCD	MDCB425203
25	25 x 3	D	#032	HCD	MDCB425253
35	20 x 2	D	#032	HCD	MDCB435202
35	20 x 3	D	#045	HCD	MDCB435203
35	25 x 3	D	#045	HCD	MDCB435253
50	20 x 3	D	#045	HCD	MDCB450203
50	25 x 2	D	#045	HCD	MDCB450252
50	25 x 3	D	#045	HCD	MDCB450253
70	25 x 3	D	#065	HCD	MDCB470253
70	25 x 4	D	#065	HCD	MDCB470254
70	25 x 6	D	#090	HCD	MDCB470256
70	40 x 6	D	#090	HCD	MDCB440670
70	50 x 6	D	#115	HCD	MDCB470506
95	25 x 3	D	#090	HCD	MDCB495253
95	25 x 4	D	#090	HCD	MDCB495254
95	25 x 5	D	#090	HCD	MDCB495255
95	25 x 6	D	#115	HCD	MDCB495256
95	40 x 6	D	#150	HCD	MDCB440695
95	50 x 6	D	#115	HCD	MDCB495506
120	25 x 5	D	#115	HCD	MDCB4120255
120	25 x 6	D	#115	HCD	MDCB4120256
120	30 x 5	D	#115	HCD	MDCB4120305
120	40 x 6	D	#115	HCD	MDCB4406120
120	50 x 6	D	#150	HCD	MDCB4120506
150	25 x 6	D	#115	HCD	MDCB4150256
150	30 x 5	D	#115	HCD	MDCB4150305
150	40 x 5	D	#115	HCD	MDCB4150405
150	50 x 6	D	#150	HCD	MDCB4150506
185	31 x 6	D	#150	HCD	MDCB4185316
185	40 x 5	D	#150	HCD	MDCB4185405
185	40 x 6	D	#150	HCD	MDCB4406185
185	50 x 5	D	#150	HCD	MDCB4185505
185	50 x 6	D	#150	HCD	MDCB4185506
240	40 x 6	D	#200	HCD	MDCB4406240
240	50 x 5	D	#200	HCD	MDCB4240505
240	50 x 6	D	#250	HCD	MDCB4240506
300	25 x 3	D	#200	HCD	MDCB4300253
300	40 x 6	D	#250	HCD	MDCB4406300
300	50 x 6	E	2 x #150	HCE	MECB4300506
300	50 x 8	E	2 x #200	HCE	MECB4300508
8 dia	20 x 3	D	#045	HCD	MDCB48S203
8 dia	25 x 3	D	#045	HCD	MDCB48S253
10 dia	25 x 3	D	#065	HCD	MDCB410S253
10 dia	25 x 4	D	#065	HCD	MDCB410S254
10 dia	25 x 6	D	#090	HCD	MDCB410S256

10, 16, 25, 35, 50, 70, 95, 120, 150, 185, 240 and 300
= stranded cable (mm²)

8 dia and 10 dia = solid copper/steel

Horizontal bar tap to horizontal cable run tee joint - CB5

A	B	°			
16	20 x 2	D	#045	HCD	MDCB516202
16	20 x 3	D	#045	HCD	MDCB516203
16	25 x 3	D	#065	HCD	MDCB516253
25	20 x 2	D	#045	HCD	MDCB525202
25	20 x 3	D	#045	HCD	MDCB525203
25	25 x 3	D	#065	HCD	MDCB525253
35	20 x 2	D	#045	HCD	MDCB535202
35	20 x 3	D	#045	HCD	MDCB535203
35	25 x 3	D	#065	HCD	MDCB535253
50	20 x 3	D	#065	HCD	MDCB550203
50	25 x 2	D	#065	HCD	MDCB550252
50	25 x 3	D	#065	HCD	MDCB550253
70	25 x 3	D	#090	HCD	MDCB570253
70	25 x 4	D	#115	HCD	MDCB570254
70	25 x 6	D	#115	HCD	MDCB570256
95	25 x 4	D	#150	HCD	MDCB595254
95	25 x 5	D	#150	HCD	MDCB595255
95	25 x 6	D	#150	HCD	MDCB595256
120	25 x 5	D	#150	HCD	MDCB5120255
120	25 x 6	D	#150	HCD	MDCB5120256
120	30 x 5	D	#200	HCD	MDCB5120305
150	25 x 6	D	#200	HCD	MDCB5150256
150	30 x 5	D	#200	HCD	MDCB5150305
150	40 x 5	D	#250	HCD	MDCB5150405
150	50 x 6	E	2 x #150	HCE	MECB5150506
185	31 x 6	D	#250	HCD	MDCB5185316
185	40 x 5	E	#250	HCE	MECB5185405
185	50 x 5	E	2 x #150	HCE	MECB5185505
240	50 x 5	E	2 x #150	HCE	MECB5240505
240	50 x 6	E	2 x #200	HCE	MECB5240506
300	50 x 6	E	2 x #250	HCE	MECB5300506
300	50 x 8	E	2 x #250	HCE	MECB5300508
8 dia	20 x 3	D	#065	HCD	MDCB58S203
8 dia	25 x 2	D	#065	HCD	MDCB58S252
8 dia	25 x 3	D	#065	HCD	MDCB58S253
10 dia	25 x 3	D	#115	HCD	MDCB510S253
10 dia	25 x 4	D	#150	HCD	MDCB510S254
10 dia	25 x 6	D	#150	HCD	MDCB510S256

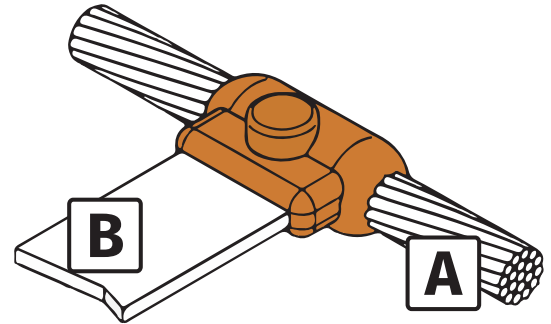

10, 16, 25, 35, 50, 70, 95, 120, 150, 185, 240 and 300
= stranded cable (mm²)

8 dia and 10 dia = solid copper/steel

Vertical flat bar end to end joint - BB1

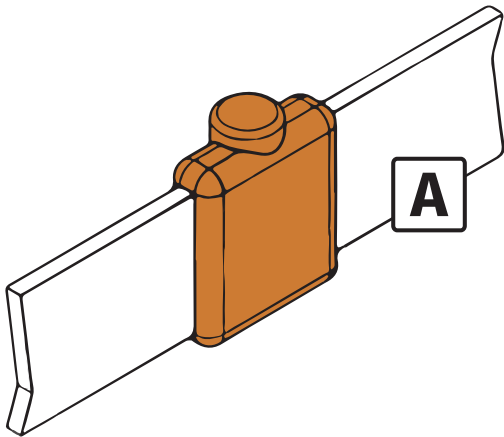



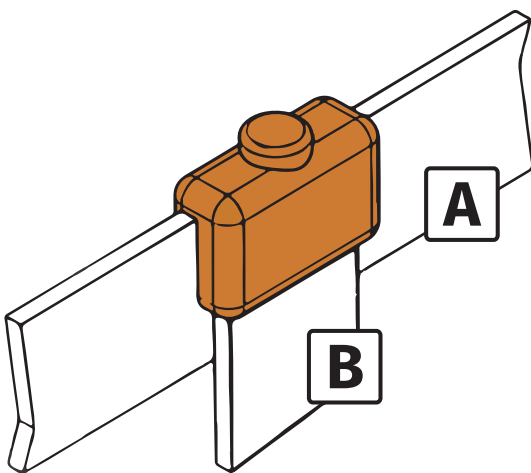

A	Ⓢ			
20 x 3	D	#045	HCD	MDBB1203
25 x 3	D	#065	HCD	MDBB1253
25 x 4	D	#090	HCD	MDBB1254
25 x 5	D	#115	HCD	MDBB1255
25 x 6	D	#150	HCD	MDBB1256
30 x 2	D	#065	HCD	MDBB1302
30 x 3	D	#090	HCD	MDBB1303
30 x 4	D	#115	HCD	MDBB1304
30 x 5	D	#115	HCD	MDBB1305
38 x 3	D	#115	HCD	MDBB1383
38 x 5	D	#150	HCD	MDBB1385
38 x 6	D	#200	HCD	MDBB1386
40 x 3	D	#115	HCD	MDBB1403
40 x 4	D	#150	HCD	MDBB1404
40 x 5	D	#150	HCD	MDBB1405
40 x 6	D	#200	HCD	MDBB1406
50 x 3	D	#150	HCD	MDBB1503
50 x 4	D	#200	HCD	MDBB1504
50 x 5	D	#200	HCD	MDBB1505
50 x 6	D	#250	HCD	MDBB1506
50 x 8	E	2 x #150	HCE	MEBB1508
60 x 6	E	#250	HCE	MEBB1606
60 x 8	E	2 x #200	HCE	MEBB1608

Bar to bar vertical joint - BB3





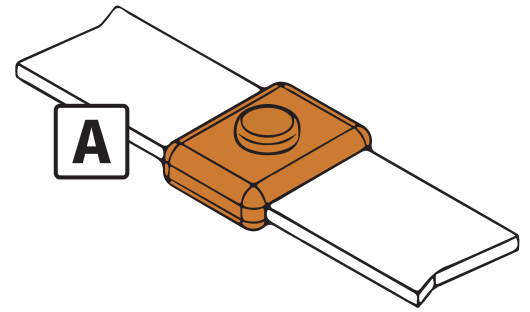

A	B	Ⓢ			
20 x 3	20 x 3	D	#065	HCD	MDBB3203203
25 x 3	25 x 3	D	#065	HCD	MDBB3253253
25 x 4	25 x 4	D	#090	HCD	MDBB3254254
25 x 5	25 x 5	D	#115	HCD	MDBB3255255
25 x 6	25 x 6	D	#150	HCD	MDBB3256256
30 x 2	30 x 2	D	#065	HCD	MDBB3302302
30 x 3	30 x 3	D	#090	HCD	MDBB3303303
30 x 4	30 x 4	D	#115	HCD	MDBB3304304
30 x 5	30 x 5	D	#115	HCD	MDBB3305305
38 x 3	38 x 3	D	#115	HCD	MDBB3383383
38 x 5	38 x 5	E	#150	HCE	MEBB3385385
38 x 6	38 x 6	E	#200	HCE	MEBB3386386
40 x 3	40 x 3	E	#115	HCE	MEBB3403403
40 x 4	40 x 4	E	#150	HCE	MEBB3404404
40 x 5	40 x 5	E	#150	HCE	MEBB3405405
40 x 6	40 x 6	E	#200	HCE	MEBB3406406
50 x 3	50 x 3	E	#200	HCE	MEBB3503503
50 x 4	50 x 4	E	#200	HCE	MEBB3504504
50 x 5	50 x 5	E	#200	HCE	MEBB3505505
50 x 6	50 x 6	E	#250	HCE	MEBB3506506
50 x 8	50 x 8	E	2 x #150	HCE	MEBB3508508
60 x 6	60 x 6	E	2 x #150	HCE	MEBB3606606
60 x 8	60 x 8	F	2 x #200	HCE	MEBB3608608

Horizontal flat bar end to end joint - BB7

A				
20 x 3	D	#045	HCD	MDBB7203
25 x 3	D	#065	HCD	MDBB7253
25 x 4	D	#090	HCD	MDBB7254
25 x 5	D	#090	HCD	MDBB7255
25 x 6	D	#115	HCD	MDBB7256
30 x 2	D	#065	HCD	MDBB7302
30 x 3	D	#065	HCD	MDBB7303
30 x 4	D	#090	HCD	MDBB7304
30 x 5	D	#115	HCD	MDBB7305
31 x 6	D	#150	HCD	MDBB7316
38 x 3	D	#090	HCD	MDBB7383
38 x 5	D	#150	HCD	MDBB7385
38 x 6	D	#200	HCD	MDBB7386
40 x 3	D	#090	HCD	MDBB7403
40 x 4	D	#115	HCD	MDBB7404
40 x 5	D	#150	HCD	MDBB7405
40 x 6	D	#200	HCD	MDBB7406
50 x 3	E	#150	HCE	MEBB7503
50 x 4	E	#200	HCE	MEBB7504
50 x 5	E	#200	HCE	MEBB7505
50 x 6	E	#250	HCE	MEBB7506
50 x 8	E	2 x #150	HCE	MEBB7508
60 x 6	E	2 x #150	HCE	MEBB7606
60 x 8	E	2 x #200	HCE	MEBB7608



Horizontal flat bar run and tap tee joint - BB14

A	B				
20 x 3	20 x 3	D	#045	HCD	MDBB14203203
25 x 3	25 x 3	D	#065	HCD	MDBB14253253
25 x 4	25 x 4	D	#090	HCD	MDBB14254254
25 x 6	25 x 6	D	#115	HCD	MDBB14256256
30 x 2	30 x 2	D	#065	HCD	MDBB14302302
30 x 3	30 x 3	D	#065	HCD	MDBB14303303
30 x 4	30 x 4	D	#090	HCD	MDBB14304304
30 x 5	30 x 5	D	#115	HCD	MDBB14305305
31 x 6	31 x 6	D	#150	HCD	MDBB14316316
38 x 3	38 x 3	D	#090	HCD	MDBB14383383
38 x 5	38 x 5	D	#150	HCD	MDBB14385385
38 x 6	38 x 6	D	#200	HCD	MDBB14386386
40 x 3	40 x 3	D	#090	HCD	MDBB14403403
40 x 4	40 x 4	D	#115	HCD	MDBB14404404
40 x 5	40 x 5	D	#150	HCD	MDBB14405405
40 x 6	40 x 6	D	#200	HCD	MDBB14406406
40 x 6	50 x 6	D	#250	HCE	MEBB14406506
50 x 3	50 x 3	E	#150	HCE	MEBB14503503
50 x 4	50 x 4	E	#200	HCE	MEBB14504504
50 x 5	50 x 5	E	#200	HCE	MEBB14505505
50 x 6	25 x 3	E	#150	HCE	MEBB14506253
50 x 6	31 x 3	E	#150	HCE	MEBB14506313
50 x 6	50 x 6	E	#250	HCE	MEBB14506506

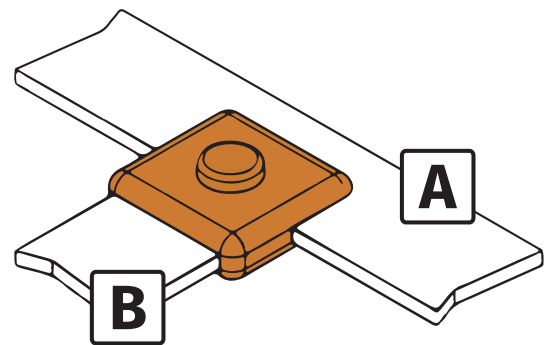



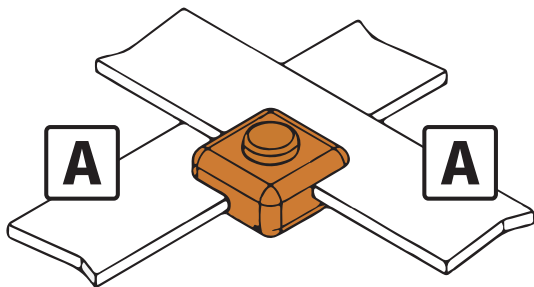

Horizontal flat bar (uncut) cross joint - BB41



A	°			
20 x 3	D	#065	HCD	MDBB41203203
25 x 3	D	#065	HCD	MDBB41253253
25 x 4	D	#090	HCD	MDBB41254254
25 x 5	D	#090	HCD	MDBB41255255
25 x 6	D	#115	HCD	MDBB41256256
30 x 2	D	#90	HCD	MDBB41302302
30 x 3	D	#115	HCD	MDBB41303303
30 x 4	D	#115	HCD	MDBB41304304
30 x 5	D	#115	HCD	MDBB41305305
31 x 6	D	#115	HCD	MDBB41316316
38 x 3	D	#150	HCD	MDBB41383383
38 x 5	D	#150	HCD	MDBB41385385
38 x 6	D	#200	HCD	MDBB41386386
40 x 3	D	#200	HCD	MDBB41403403
40 x 4	D	#200	HCD	MDBB41404404
40 x 5	D	#200	HCD	MDBB41405405
40 x 6	D	#200	HCD	MDBB41406406
50 x 3	E	#200	HCE	MEBB41503503
50 x 4	E	#200	HCE	MEBB41504504
50 x 5	E	#200	HCE	MEBB41505505
50 x 6	E	#200	HCE	MEBB41506506

Horizontal parallel cable to horizontal rebar joint - CRE1

A	B				
16	10 - 40	D	#045	HCD*	MDCRE116
25	10 - 40	D	#045	HCD*	MDCRE125
35	10 - 40	D	#045	HCD*	MDCRE135
50	10 - 40	D	#090	HCD*	MDCRE150
70	10 - 40	D	#090	HCD*	MDCRE170
95	10 - 40	D	#090	HCD*	MDCRE195
120	10 - 40	D	#090	HCD*	MDCRE1120
8 dia	10 - 40	D	#090	HCD*	MDCRE18S
10 dia	10 - 40	D	#090	HCD*	MDCRE110S

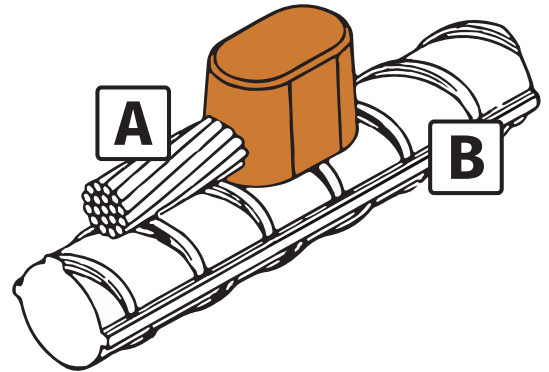

*Requires chain clamp and butyl seal

16, 25, 35, 50, 70, 95 and 120 = stranded cable (mm²)

8 dia and 10 dia = solid copper/steel

Horizontal rebar to horizontal cable tee joint - CRE2

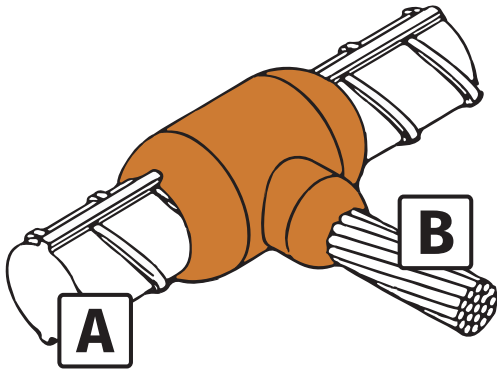

A	B	Ⓢ	🪵	🔪	📦
16	16	D	#090	HCD*	MDCRE216R16
16	25	D	#090	HCD*	MDCRE216R25
16	35	D	#090	HCD*	MDCRE216R35
16	50	D	#115	HCD*	MDCRE216R50
16	70	D	#115	HCD*	MDCRE216R70
16	95	D	#150	HCD*	MDCRE216R95
16	120	D	#150	HCD*	MDCRE216R120
16	150	D	#200	HCD*	MDCRE216R150
16	185	D	#200	HCD*	MDCRE216R185
16	240	D	#250	HCD*	MDCRE216R240
16	300	E	2 x #150	HCE*	MECRE216R300
18	16	D	#115	HCD*	MDCRE218R16
18	25	D	#115	HCD*	MDCRE218R25
18	35	D	#115	HCD*	MDCRE218R35
18	50	D	#150	HCD*	MDCRE218R50
18	70	D	#150	HCD*	MDCRE218R70
18	95	D	#150	HCD*	MDCRE218R95
18	120	D	#200	HCD*	MDCRE218R120
18	150	D	#200	HCD*	MDCRE218R150
18	185	D	#200	HCD*	MDCRE218R185
18	240	D	#250	HCD*	MDCRE218R240
18	300	E	2 x #150	HCE*	MECRE218R300
20	16	D	#115	HCD*	MDCRE220R16
20	25	D	#115	HCD*	MDCRE220R25
20	35	D	#115	HCD*	MDCRE220R35
20	50	D	#150	HCD*	MDCRE220R50
20	70	D	#150	HCD*	MDCRE220R70
20	95	D	#200	HCD*	MDCRE220R95
20	120	D	#200	HCD*	MDCRE220R120
20	150	D	#200	HCD*	MDCRE220R150
20	185	D	#250	HCD*	MDCRE220R185
20	240	E	2 x #150	HCE*	MECRE220R240
20	300	E	2 x #200	HCE*	MECRE220R300
25	16	D	#200	HCD*	MDCRE225R16
25	25	D	#200	HCD*	MDCRE225R25
25	35	D	#200	HCD*	MDCRE225R35
25	50	D	#200	HCD*	MDCRE225R50
25	70	D	#250	HCD*	MDCRE225R70
25	95	D	#250	HCD*	MDCRE225R95
25	120	D	#250	HCD*	MDCRE225R120
25	150	E	2 x #150	HCE*	MECRE225R150

*Requires chain clamp and butyl seal

Horizontal thru cable to vertical rebar joint - CRE3

A	B	Ⓢ	Ⓢ	✂	Ⓢ
16	10 - 40	D	#045	HCD*	MDCRE316
25	10 - 40	D	#045	HCD*	MDCRE325
35	10 - 40	D	#045	HCD*	MDCRE335
50	10 - 40	D	#090	HCD*	MDCRE350
70	10 - 40	D	#090	HCD*	MDCRE370
95	10 - 40	D	#090	HCD*	MDCRE395
120	10 - 40	D	#090	HCD*	MDCRE3120
8 dia	10 - 40	D	#090	HCD*	MDCRE38S
10 dia	10 - 40	D	#090	HCD*	MDCRE310S

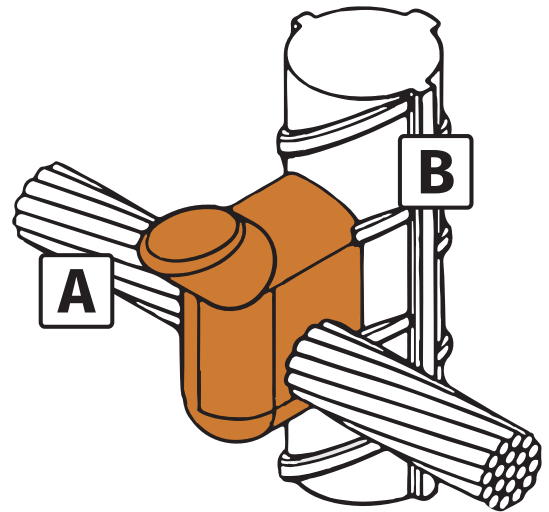

*Requires chain clamp and butyl seal

16, 25, 35, 50, 70, 95 and 120 = stranded cable (mm²)

8 dia and 10 dia = solid copper/steel

Horizontal cable tap to vertical rebar joint - CRE6

A	B	Ⓢ	Ⓢ	✂	Ⓢ
16	10 - 40	D	#045	HCD*	MDCRE616
25	10 - 40	D	#045	HCD*	MDCRE625
35	10 - 40	D	#045	HCD*	MDCRE635
50	10 - 40	D	#065	HCD*	MDCRE650
70	10 - 40	D	#090	HCD*	MDCRE670
95	10 - 40	D	#090	HCD*	MDCRE695
120	10 - 40	D	#090	HCD*	MDCRE6120
8 dia	10 - 40	D	#065	HCD*	MDCRE68S
10 dia	10 - 40	D	#090	HCD*	MDCRE610S

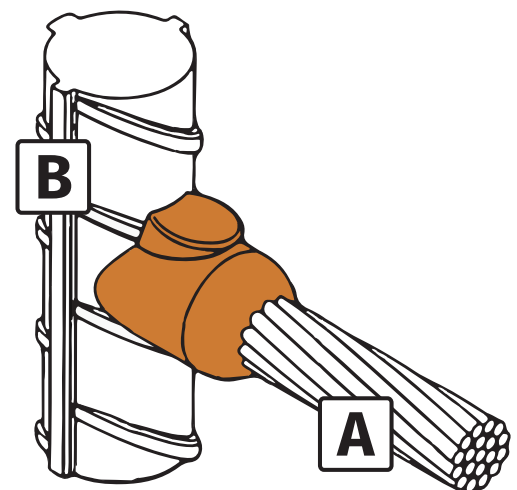

*Requires chain clamp and butyl seal

16, 25, 35, 50, 70, 95 and 120 = stranded cable (mm²)

8 dia and 10 dia = solid copper/steel

Horizontal cable to horizontal rebar joint - CRE17

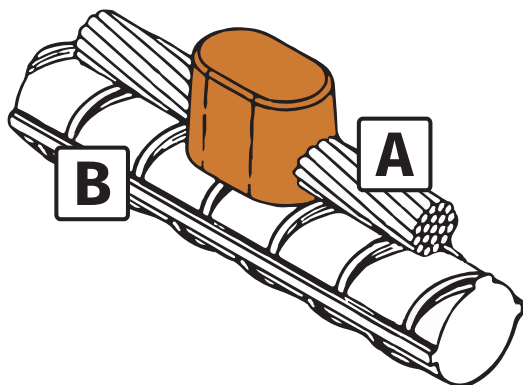

A	B	°	Icon 1	Icon 2	Icon 3
16	10 - 40	D	#045	HCD	MDCRE1716
25	10 - 40	D	#045	HCD	MDCRE1725
35	10 - 40	D	#045	HCD	MDCRE1735
50	10 - 40	D	#090	HCD	MDCRE1750
70	10 - 40	D	#090	HCD	MDCRE1770
95	10 - 40	D	#090	HCD	MDCRE1795
120	10 - 40	D	#090	HCD	MDCRE17120
8 dia	10 - 40	D	#090	HCD	MDCRE178S
10 dia	10 - 40	D	#090	HCD	MDCRE1710S

*Requires chain clamp and butyl seal

16, 25, 35, 50, 70, 95 and 120 = stranded cable (mm²)

8 dia and 10 dia = solid copper/steel

Horizontal bar terminal to ground rod joint - BR1

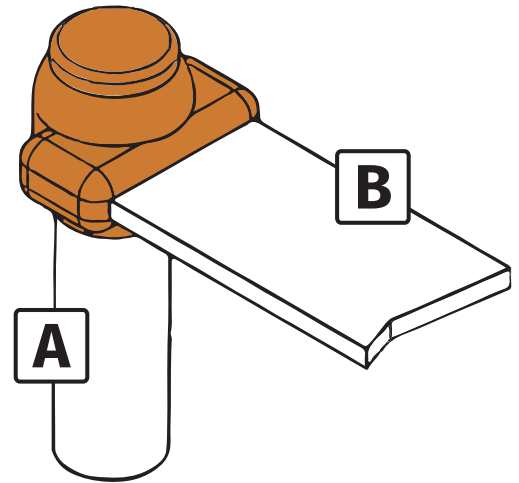

A	B	°			
12.7	20 x 3	D	#090	HCD	MDBR112.7203
12.7	25 x 3	D	#090	HCD	MDBR112.7253
12.7	25 x 4	D	#090	HCD	MDBR112.7254
12.7	30 x 2	D	#090	HCD	MDBR112.7302
12.7	30 x 3	D	#090	HCD	MDBR112.7303
12.7	31 x 3	D	#090	HCD	MDBR112.7313
12.7	38 x 3	D	#090	HCD	MDBR112.7383
12.7	40 x 3	D	#090	HCD	MDBR112.7403
12.7	50 x 3	D	#115	HCD	MDBR112.7503
12.7	50 x 6	D	#115	HCD	MDBR112.7506
14.2	20 x 3	D	#090	HCD	MDBR114.2203
14.2	25 x 3	D	#090	HCD	MDBR114.2253
14.2	25 x 4	D	#115	HCD	MDBR114.2254
14.2	25 x 6	D	#115	HCD	MDBR114.2256
14.2	30 x 2	D	#115	HCD	MDBR114.2302
14.2	30 x 3	D	#115	HCD	MDBR114.2303
14.2	30 x 4	D	#150	HCD	MDBR114.2304
14.2	30 x 5	D	#150	HCD	MDBR114.2305
14.2	38 x 3	D	#115	HCD	MDBR114.2383
14.2	38 x 5	D	#150	HCD	MDBR114.2385
14.2	38 x 6	D	#200	HCD	MDBR114.2386
14.2	40 x 3	D	#115	HCD	MDBR114.2403
14.2	40 x 4	D	#150	HCD	MDBR114.2404
14.2	40 x 5	D	#150	HCD	MDBR114.2405
14.2	40 x 6	D	#200	HCD	MDBR114.2406
14.2	50 x 3	D	#150	HCD	MDBR114.2503
14.2	50 x 4	D	#200	HCD	MDBR114.2504
14.2	50 x 5	D	#200	HCD	MDBR114.2505
14.2	50 x 6	D	#200	HCD	MDBR114.2506
17.2	20 x 3	D	#115	HCD	MDBR117.2203
17.2	25 x 3	D	#150	HCD	MDBR117.2253
17.2	25 x 4	D	#200	HCD	MDBR117.2254
17.2	25 x 6	D	#200	HCD	MDBR117.2256
17.2	30 x 2	D	#150	HCD	MDBR117.2302
17.2	30 x 3	D	#150	HCD	MDBR117.2303
17.2	30 x 4	D	#250	HCD	MDBR117.2304
17.2	30 x 5	D	#250	HCD	MDBR117.2305
17.2	38 x 3	D	#250	HCD	MDBR117.2383
17.2	38 x 5	D	#200	HCD	MDBR117.2385
17.2	38 x 6	D	#250	HCD	MDBR117.2386
17.2	40 x 3	D	#200	HCD	MDBR117.2403
17.2	40 x 4	D	#200	HCD	MDBR117.2404
17.2	40 x 5	D	#200	HCD	MDBR117.2405
17.2	40 x 6	E	2 x #150	HCE	MEBR117.2406
17.2	50 x 3	E	2 x #150	HCE	MEBR117.2503
17.2	50 x 4	E	2 x #150	HCE	MEBR117.2504
17.2	50 x 5	E	2 x #150	HCE	MEBR117.2505
17.2	50 x 6	E	2 x #200	HCE	MEBR117.2506
16	25 x 3	D	#90	HCD	MDBR116253
16	50 x 3	E	#150	HCE	MEBR116503
16	50 x 6	E	#200	HCE	MEBR116506
20	25 x 3	D	#150	HCD	MDBR120253
20	25 x 6	D	#200	HCD	MDBR120256
20	50 x 6	E	2 x #200	HCE	MEBR120506



12.7, 14.2 and 17.2 = copperbond / 16 and 20 = solid copper/steel

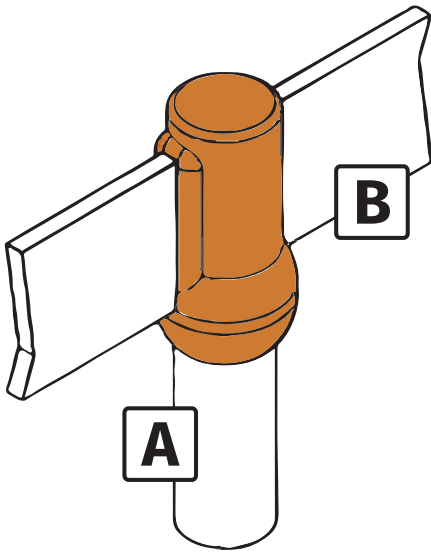



Horizontal bar terminal to ground rod joint - BR2



A	B	Ⓢ			
12.7	20 x 3	D	#090	HCD	MDBR212.7203
12.7	25 x 3	D	#090	HCD	MDBR212.7253
12.7	25 x 4	D	#090	HCD	MDBR212.7254
12.7	30 x 2	D	#090	HCD	MDBR212.7302
12.7	30 x 3	D	#090	HCD	MDBR212.7303
12.7	38 x 3	D	#090	HCD	MDBR212.7383
12.7	40 x 3	D	#090	HCD	MDBR212.7403
12.7	50 x 3	D	#115	HCD	MDBR212.7503
12.7	50 x 6	D	#250	HCD	MDBR212.7506
14.2	20 x 3	D	#090	HCD	MDBR214.2203
14.2	25 x 3	D	#090	HCD	MDBR214.2253
14.2	25 x 4	D	#115	HCD	MDBR214.2254
14.2	25 x 5	D	#115	HCD	MDBR214.2255
14.2	25 x 6	D	#150	HCD	MDBR214.2256
14.2	30 x 2	D	#090	HCD	MDBR214.2302
14.2	30 x 3	D	#115	HCD	MDBR214.2303
14.2	30 x 4	D	#150	HCD	MDBR214.2304
14.2	30 x 5	D	#150	HCD	MDBR214.2305
14.2	30 x 6	D	#150	HCD	MDBR214.2306
14.2	31 x 3	D	#115	HCD	MDBR214.2313
14.2	31 x 6	D	#150	HCD	MDBR214.2316
14.2	38 x 3	D	#150	HCD	MDBR214.2383
14.2	38 x 5	D	#150	HCD	MDBR214.2385
14.2	38 x 6	D	#200	HCD	MDBR214.2386
14.2	40 x 3	D	#150	HCD	MDBR214.2403
14.2	40 x 4	D	#150	HCD	MDBR214.2404
14.2	40 x 5	D	#150	HCD	MDBR214.2405
14.2	40 x 6	D	#200	HCD	MDBR214.2406
14.2	50 x 3	D	#200	HCD	MDBR214.2503
14.2	50 x 4	D	#200	HCD	MDBR214.2504
14.2	50 x 5	D	#200	HCD	MDBR214.2505
14.2	50 x 6	D	#250	HCD	MDBR214.2506
17.2	20 x 3	D	#150	HCD	MDBR217.2203
17.2	25 x 3	D	#150	HCD	MDBR217.2253
17.2	25 x 4	D	#200	HCD	MDBR217.2254
17.2	25 x 6	D	#200	HCD	MDBR217.2256
17.2	30 x 2	D	#150	HCD	MDBR217.2302
17.2	30 x 3	D	#150	HCD	MDBR217.2303
17.2	30 x 4	D	#250	HCD	MDBR217.2304
17.2	30 x 5	D	#200	HCD	MDBR217.2305
17.2	38 x 3	D	#200	HCD	MDBR217.2383
17.2	38 x 5	D	#200	HCD	MDBR217.2385
17.2	38 x 6	D	#250	HCD	MDBR217.2386
17.2	40 x 3	D	#200	HCD	MDBR217.2403
17.2	40 x 4	D	#200	HCD	MDBR217.2404
17.2	40 x 5	D	#200	HCD	MDBR217.2405
17.2	40 x 6	D	#250	HCD	MDBR217.2406
17.2	50 x 3	E	2 x #150	HCE	MEBR217.2503
17.2	50 x 4	E	2 x #150	HCE	MEBR217.2504
17.2	50 x 5	E	2 x #150	HCE	MEBR217.2505
17.2	50 x 6	E	2 x #150	HCE	MEBR217.2506
16	25 x 3	D	#90	HCD	MDBR216253
20	25 x 3	D	#200	HCD	MDBR220253

12.7, 14.2 and 17.2 = copperbond / 16 and 20 = solid copper/steel

Earth rod to bar tee horizontal tape - BR7

A	B				
14.2	25 x 3	D	#150	HCD	MDBR714.2253
14.2	25 x 6	D	#115	HCD	MDBR714.2256
14.2	50 x 6	E	#200	HCE	MEBR714.2506
17.2	25 x 3	D	#150	HCD	MDBR717.2253
17.2	50 x 6	E	#200	HCE	MEBR717.2506
16	25 x 3	D	#150	HCD	MDBR716253
16	25 x 6	D	#200	HCD	MDBR716256
16	50 x 6	E	#200	HCE	MEBR716506
20	25 x 3	D	#150	HCD	MDBR720253

14.2 and 17.2 = copperbond / 16 and 20 = solid copper/steel

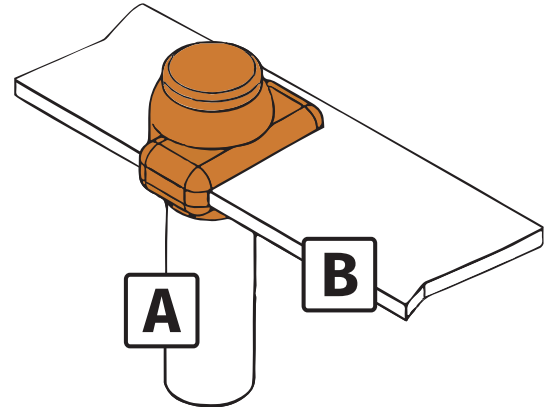

45° cable to vertical steel surface joint - CS3

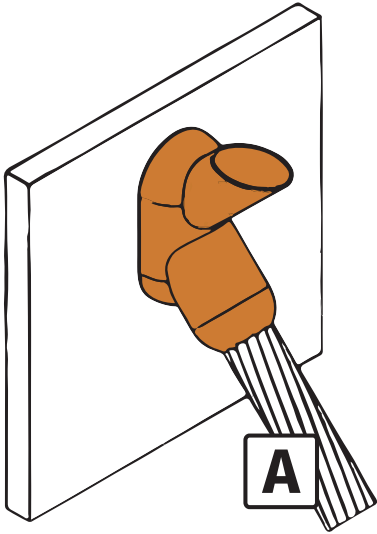

A	°	Icon	Icon	Icon
16	D	#045	HCD*	MDCS316
25	D	#045	HCD*	MDCS325
35	D	#045	HCD*	MDCS335
50	D	#065	HCD*	MDCS350
70	D	#090	HCD*	MDCS370
95	D	#115	HCD*	MDCS395
120	D	#115	HCD*	MDCS3120
150	D	#115	HCD*	MDCS3150
185	D	#200	HCD*	MDCS3185
240	D	#200	HCD*	MDCS3240
300	D	#250	HCD*	MDCS3300
8 dia	D	#065	HCD*	MDCS38S
10 dia	D	#090	HCD*	MDCS310S

*Requires chain clamp

16, 25, 35, 50, 70, 95, 120, 150, 185, 240 and 300
= stranded cable (mm²)

8 dia and 10 dia = solid copper/steel

Vertical cable (upwards) to vertical steel surface joint - CS7

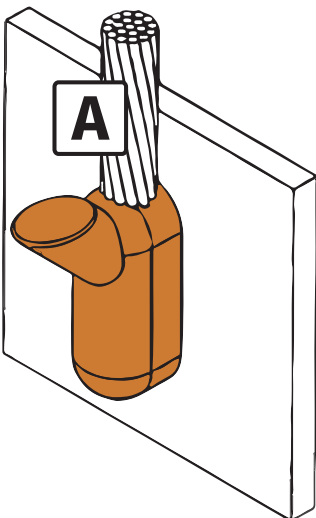





A	°	Icon	Icon	Icon
16	D	#045	HCD*	MDCS716
25	D	#065	HCD*	MDCS725
35	D	#065	HCD*	MDCS735
50	D	#090	HCD*	MDCS750
70	D	#150	HCD*	MDCS770
95	D	#200	HCD*	MDCS795
120	D	#200	HCD*	MDCS7120
150	D	#250	HCD*	MDCS7150
185	E	2 x #150	HCE*	MECS7185
240	E	2 x #150	HCE*	MECS7240
300	E	2 x #200	HCE*	MECS7300
8 dia	D	#090	HCD*	MDCS78S
10 dia	D	#150	HCD*	MDCS710S

*Requires chain clamp

16, 25, 35, 50, 70, 95, 120, 150, 185, 240 and 300
= stranded cable (mm²)

8 dia and 10 dia = solid copper/steel

Horizontal cable to horizontal steel surface joint - CS8



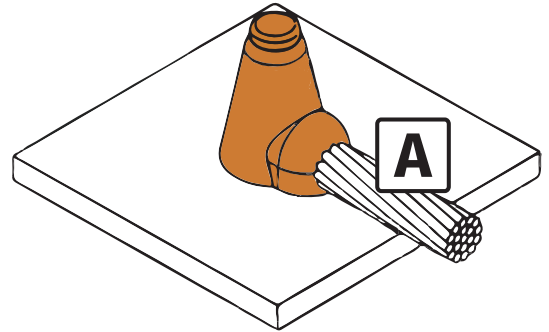

A				
10	A	#025	HCCP75	MACS810
16	A	#025	HCCP75	MACS816
25	A	#032	HCCP75	MACS825
35	A	#032	HCCP75	MACS835
50	B	#045	HCCP75	MBCS850
70	B	#065	HCCP75	MBCS870
95	C	#090	HCCP100	MCCS895
120	D	#115	HCCP100	MDCS8120
150	D	#150	HCCP100	MDCS8150
185	D	#200	HCCP100	MDCS8185
240	D	#200	HCCP100	MDCS8240
300	D	#250	HCCP100	MDCS8300
8 dia	C	#045	HCCP100	MCCS885
10 dia	C	#065	HCCP100	MCCS810S



10, 16, 25, 35, 50, 70, 95, 120, 150, 185, 240 and 300 = stranded cable (mm²)

8 dia and 10 dia = solid copper/steel

Horizontal thru cable to horizontal steel surface joint - CS9

A				
10	A	#025	HCCP75	MACS910
16	A	#025	HCCP75	MACS916
25	A	#032	HCCP75	MACS925
35	A	#045	HCCP75	MACS935
50	B	#090	HCCP75	MBCS950
70	D	#115	HCCP75	MDCS970
95	D	#115	HCCP100	MDCS995
120	D	#150	HCCP100	MDCS9120
150	D	#200	HCCP100	MDCS9150
185	D	#250	HCCP100	MDCS9185
240	E	2 x #200	HCCP100	MECS9240
300	E	2 x #250	HCCP100	MECS9300
8 dia	D	#090	HCCP75	MDCS985
10 dia	D	#115	HCCP75	MDCS910S

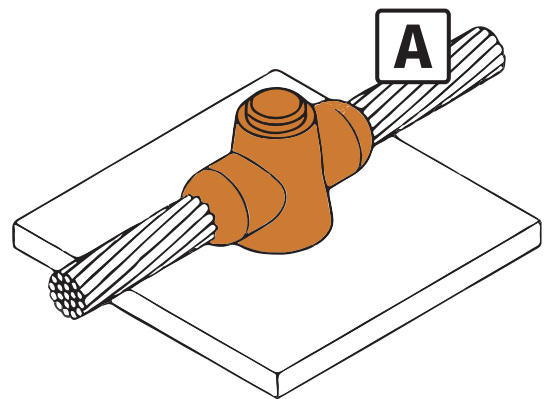

10, 16, 25, 35, 50, 70, 95, 120, 150, 185, 240 and 300 = stranded cable (mm²)

8 dia and 10 dia = solid copper/steel

Vertical cable (downwards) to vertical steel surface joint - CS25

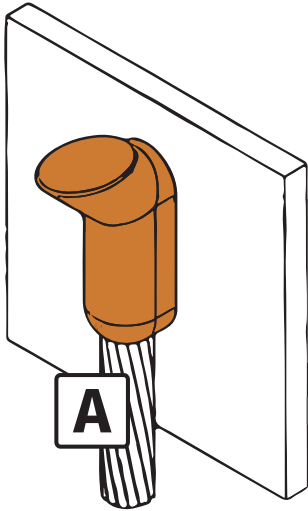

A	\$	Icon	Icon	Icon
16	D	#045	HCD*	MDCS2516
25	D	#045	HCD*	MDCS2525
35	D	#045	HCD*	MDCS2535
50	D	#065	HCD*	MDCS2550
70	D	#090	HCD*	MDCS2570
95	D	#115	HCD*	MDCS2595
120	D	#115	HCD*	MDCS25120
150	D	#150	HCD*	MDCS25150
185	D	#200	HCD*	MDCS25185
240	D	#200	HCD*	MDCS25240
300	D	#250	HCD*	MDCS25300
8 dia	D	#065	HCD*	MDCS258S
10 dia	D	#090	HCD*	MDCS2510S

*Requires chain clamp

16, 25, 35, 50, 70, 95, 120, 150, 185, 240 and 300 = stranded cable (mm²)

8 dia and 10 dia = solid copper/steel

Horizontal thru cable to vertical steel surface joint - CS27

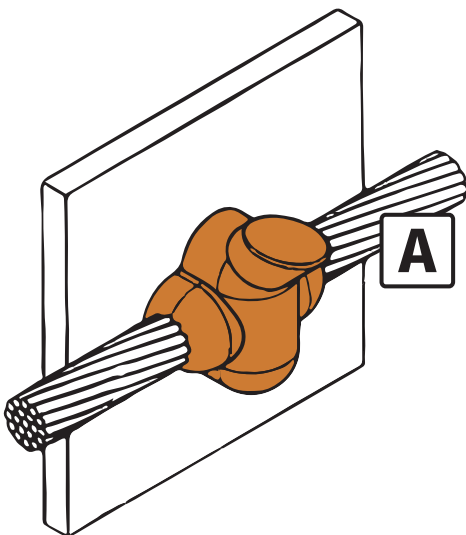





A	\$	Icon	Icon	Icon
16	D	#045	HCD	MDCS2716
25	D	#045	HCD	MDCS2725
35	D	#045	HCD	MDCS2735
50	D	#065	HCD	MDCS2750
70	D	#115	HCD	MDCS2770
95	D	#150	HCD	MDCS2795
120	D	#150	HCD	MDCS27120
150	D	#200	HCD	MDCS27150
185	D	#250	HCD	MDCS27185
240	E	2 x #150	HCD	MECS27240
300	E	2 x #200	HCD	MECS27300
8 dia	D	#065	HCD	MDCS278S
10 dia	D	#115	HCD	MDCS2710S

*Requires chain clamp

10, 16, 25, 35, 50, 70, 95, 120, 150, 185, 240 and 300 = stranded cable (mm²)

8 dia and 10 dia = solid copper/steel

Horizontal cable to horizontal steel pipe joint - CS32

A				
16	A	#025	HCCP75	MACS3216
25	A	#025	HCCP75	MACS3225
35	A	#032	HCCP75	MACS3235
50	A	#045	HCCP75	MACS3250
70	B	#065	HCCP75	MBCS3270
95	D	#090	HCD	MDCS3295
120	D	#115	HCD	MDCS32120
150	D	#150	HCD	MDCS32150
185	D	#200	HCD	MDCS32185
240	D	#200	HCD	MDCS32240
300	D	#200	HCD	MDCS32300
8 dia	B	#045	HCCP75	MBCS328S
10 dia	B	#065	HCCP75	MBCS3210S

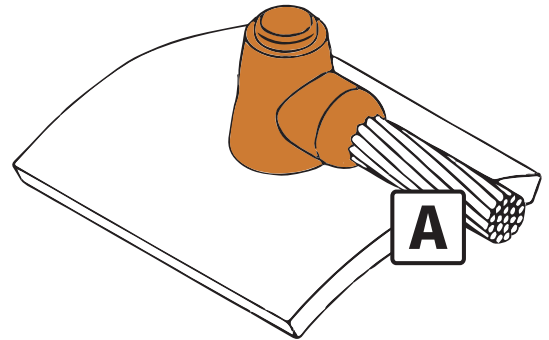





*State pipe diameter when ordering moulds

10, 16, 25, 35, 50, 70, 95, 120, 150, 185, 240 and 300
= stranded cable (mm²)

8 dia and 10 dia = solid copper/steel

Horizontal thru cable to horizontal steel pipe joint - CS34

A				
10	A	#025	HCCP75	MACS3410
16	A	#025	HCCP75	MACS3416
25	A	#032	HCCP75	MACS3425
35	A	#045	HCCP75	MACS3435
50	A	#090	HCCP75	MACS3450
70	A	#115	HCD	MACS3470
95	D	#115	HCD	MDCS3495
120	D	#150	HCD	MDCS34120
150	D	#200	HCD	MDCS34150
185	D	#250	HCD	MDCS34185
240	E	2 x #150	HCE	MECS34240
8 dia	A	#090	HCCP75	MACS348S
10 dia	D	#115	HCCP75	MDCS3410S

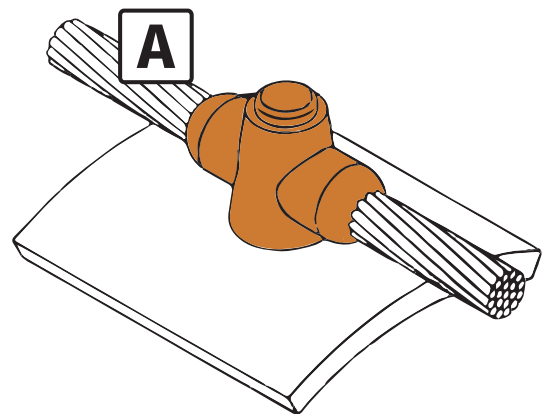

*State pipe diameter when ordering moulds

10, 16, 25, 35, 50, 70, 95, 120, 150, 185, 240 and 300
= stranded cable (mm²)

8 dia and 10 dia = solid copper/steel

Vertical bar to vertical steel surface joint - BS1

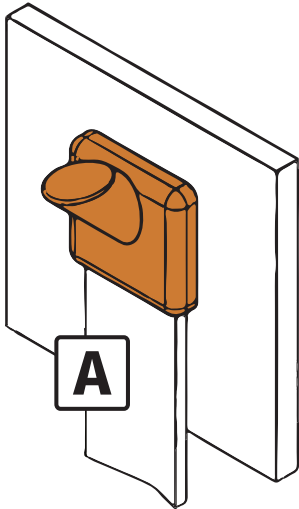

A	Ⓢ	🗑️	🔧	📦
20 x 3	D	#065	HCD*	MDBS1203
25 x 3	D	#090	HCD*	MDBS1253
25 x 4	D	#090	HCD*	MDBS1254
25 x 6	D	#150	HCD*	MDBS1256
30 x 2	D	#090	HCD*	MDBS1302
30 x 3	D	#090	HCD*	MDBS1303
30 x 4	D	#115	HCD*	MDBS1304
30 x 5	D	#150	HCD*	MDBS1305
38 x 3	D	#150	HCD*	MDBS1383
38 x 5	D	#200	HCD*	MDBS1385
38 x 6	D	#250	HCD*	MDBS1386
40 x 3	D	#150	HCD*	MDBS1403
40 x 4	D	#200	HCD*	MDBS1404
40 x 5	D	#200	HCD*	MDBS1405
40 x 6	D	#250	HCD*	MDBS1406
50 x 3	D	#200	HCD*	MDBS1503
50 x 4	D	#250	HCD*	MDBS1504
50 x 5	D	#250	HCD*	MDBS1505
50 x 6	E	2 x #150	HCE*	MEBS1506
50 x 8	E	2 x #200	HCE*	MEBS1508
60 x 6	E	2 x #200	HCE*	MEBS1606
60 x 8	F	2 x #250	HCE*	MFBS1608
60 x 10	F	3 x #200	HCE*	MFBS16010



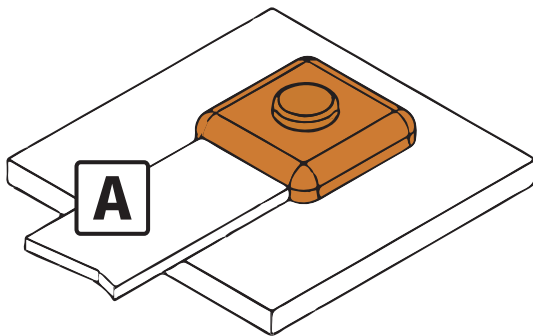

*Requires chain clamp

Horizontal bar to horizontal steel surface joint - BS2



A	Ⓢ	🗑️	🔧	📦
20 x 3	D	#090	HCD	MDBS2203
25 x 3	D	#090	HCD	MDBS2253
25 x 4	D	#090	HCD	MDBS2254
25 x 6	D	#150	HCD	MDBS2256
30 x 2	D	#115	HCD	MDBS2302
30 x 3	D	#115	HCD	MDBS2303
30 x 4	D	#150	HCD	MDBS2304
30 x 5	D	#200	HCD	MDBS2305
38 x 3	D	#150	HCD	MDBS2383
38 x 5	D	#200	HCD	MDBS2385
38 x 6	D	#200	HCD	MDBS2386
40 x 3	D	#115	HCD	MDBS2403
40 x 4	D	#200	HCD	MDBS2404
40 x 5	D	#200	HCD	MDBS2405
40 x 6	D	#250	HCD	MDBS2406
50 x 3	D	#200	HCD	MDBS2503
50 x 4	E	2 x #150	HCE	MEBS2504
50 x 5	E	2 x #150	HCE	MEBS2505
50 x 6	E	2 x #150	HCE	MEBS2506
50 x 8	E	2 x #200	HCE	MEBS2508

Horizontal thru bar to horizontal steel surface joint - BS3

A				
20 x 3	D	#090	HCD	MDBS3203
25 x 3	D	#115	HCD	MDBS3253
25 x 4	D	#115	HCD	MDBS3254
30 x 2	D	#115	HCD	MDBS3302
30 x 3	D	#115	HCD	MDBS3303
30 x 4	D	#150	HCD	MDBS3304
30 x 5	D	#200	HCD	MDBS3305
38 x 3	D	#150	HCD	MDBS3383
38 x 5	D	#200	HCD	MDBS3385
38 x 6	D	#250	HCD	MDBS3386
40 x 3	D	#150	HCD	MDBS3403
40 x 4	D	#200	HCD	MDBS3404
40 x 5	D	#250	HCD	MDBS3405
40 x 6	D	#250	HCD	MDBS3406
50 x 3	D	#250	HCD	MDBS3503
50 x 4	D	#250	HCD	MDBS3504
50 x 5	D	#250	HCD	MDBS3505
50 x 6	D	#250	HCD	MDBS3506

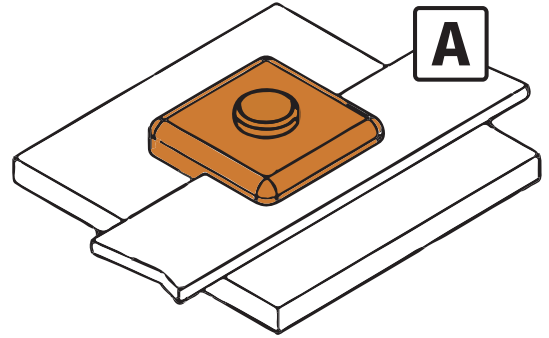

Stud to vertical steel surface - RS1

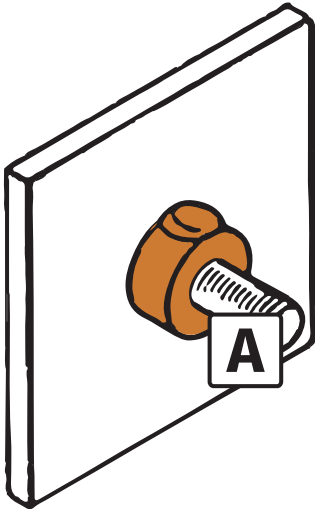

A	\$	Icon: Powder	Icon: Tongs	Icon: Box
M6	D	#025	HCD*	MDRS1M6
M8	D	#032	HCD*	MDRS1M8
M10	D	#045	HCD*	MDRS1M10
M12	D	#065	HCD*	MDRS1M12
M16	D	#115	HCD*	MDRS1M16



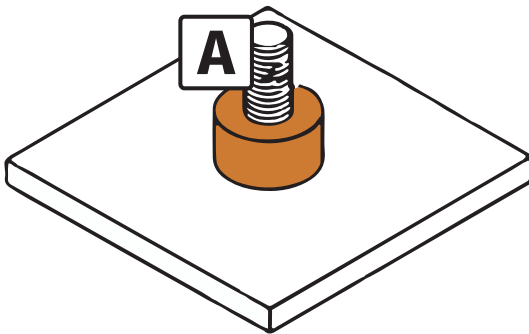

*Requires chain clamp

Stud to horizontal steel surface - RS2



A	\$	Icon: Powder	Icon: Tongs	Icon: Box
M6	D	#025	HCD	MDRS2M6
M8	D	#032	HCD	MDRS2M8
M10	D	#045	HCD	MDRS2M10
M12	D	#065	HCD	MDRS2M12
M16	D	#115	HCD	MDRS2M16

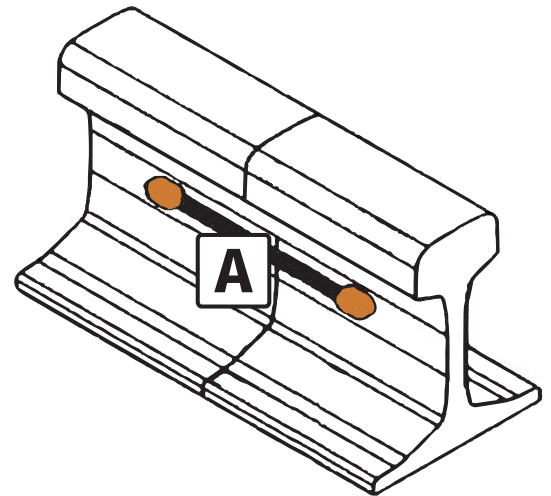

Cable to rail web - R4

A					
16	HD16	F	#045	HCRW	MFR416L
16	HD16	F	#045	HCRW	MFR416R
25	HD25	F	#045	HCRW	MFR425L
25	HD25	F	#045	HCRW	MFR425R
35	HD35	F	#045	HCRW	MFR435L
35	HD35	F	#045	HCRW	MFR435R
50	HD50	F	#065	HCRW	MFR450L
50	HD50	F	#065	HCRW	MFR450R
70	HD70	F	#090	HCRW	MFR470L
70	HD70	F	#090	HCRW	MFR470R
95	HD95	F	#090	HCRW	MFR495L
95	HD95	F	#090	HCRW	MFR495R
120	HD120	F	#115	HCRW	MFR4120L
120	HD120	F	#115	HCRW	MFR4120R
150	HD150	F	#150	HCRW	MFR4150L
150	HD150	F	#150	HCRW	MFR4150R



Mould part code suffix L denotes left hand rail
 Mould part code suffix R denotes right hand rail

Horizontal flat tape to rail flange/foot - R6

A				
25 x 3	B	#065	HCCP75	MBR6253

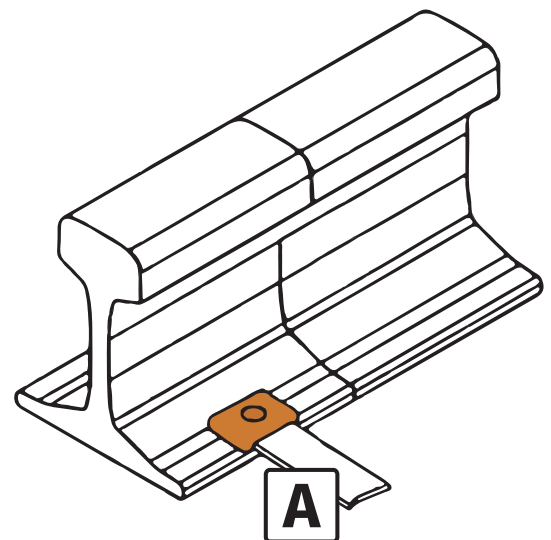

Cable to rail flange/foot - R10

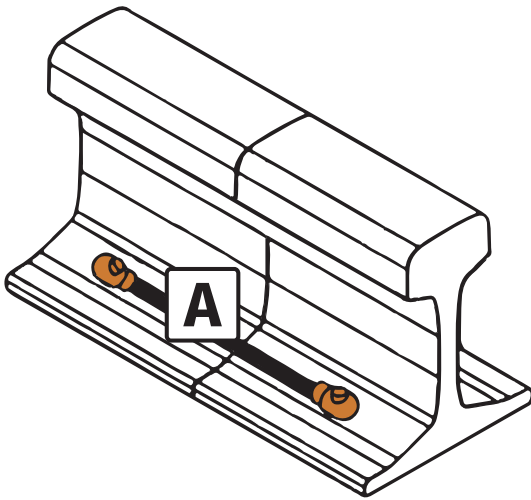

A						
16	KWF016	HD16	A	#025	HCCP75	MAR1016L
16	KWF016	HD16	A	#025	HCCP75	MAR1016R
25	KWF025	HD25	A	#025	HCCP75	MAR1025L
25	KWF025	HD25	A	#025	HCCP75	MAR1025R
35	KWF035	HD35	A	#032	HCCP75	MAR1035L
35	KWF035	HD35	A	#032	HCCP75	MAR1035R
50	KWF050	HD50	B	#045	HCCP75	MBR1050L
50	KWF050	HD50	B	#045	HCCP75	MBR1050R
70	KWF070	HD70	B	#065	HCCP75	MBR1070L
70	KWF070	HD70	B	#065	HCCP75	MBR1070R
95	KWF095	HD95	B	#065	HCCP75	MBR1095L
95	KWF095	HD95	B	#065	HCCP75	MBR1095R
120	KWF0120	HD120	B	#090	HCCP75	MBR10120L
120	KWF0120	HD120	B	#090	HCCP75	MBR10120R
150	KWF0150	HD150	B	#115	HCCP75	MBR10150L
150	KWF0150	HD150	B	#115	HCCP75	MBR10150R

Mould part code suffix L denotes left hand rail

Mould part code suffix R denotes right hand rail

Cable to rail crown - R12

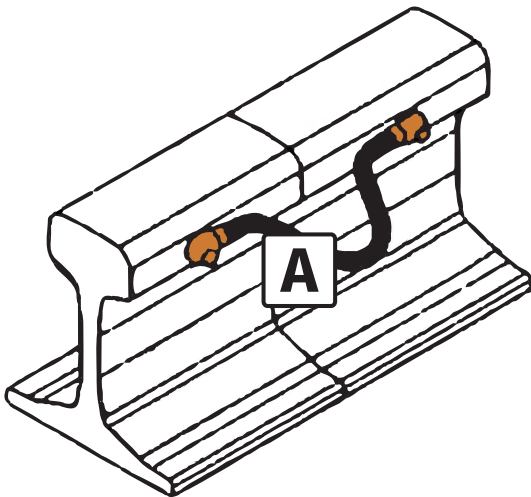

A						
25	KWF025	HD25	C	#032	HCRC	MCR1225L
25	KWF025	HD25	C	#032	HCRC	MCR1225R
35	KWF035	HD35	C	#032	HCRC	MCR1235L
35	KWF035	HD35	C	#032	HCRC	MCR1235R
50	KWF050	HD50	C	#045	HCRC	MCR1250L
50	KWF050	HD50	C	#045	HCRC	MCR1250R
70	KWF070	HD70	C	#065	HCRC	MCR1270L
70	KWF070	HD70	C	#065	HCRC	MCR1270R
95	KWF095	HD95	C	#090	HCRC	MCR1295L
95	KWF095	HD95	C	#090	HCRC	MCR1295R
120	KWF0120	HD120	C	#115	HCRC	MCR12120L
120	KWF0120	HD120	C	#115	HCRC	MCR12120L

Mould part code suffix L denotes left hand rail

Mould part code suffix R denotes right hand rail

Exothermic welding accessories

Part number	Item description
MS34	Mould scraper to suit type C moulds
MS55	Mould scraper to suit type D moulds
MS65	Mould scraper to suit type E/F moulds
RSC	Rail crown scraper
RWSC	Rail web scraper
RFSC	Rail foot scraper
CBM	Graphite mould cleaning brush
FBRUSH	Conductor cleaning brush
YBRUSH	Conductor cleaning brush (Y-shaped)
FIGN	Flint ignitor
IGNFL	Spare flints (9 per container)
SEAP	0.5kg sealing putty
MSC	Mould support clamp
HD35	Hammer die 35mm ²
HD50	Hammer die 50mm ²
HD70	Hammer die 70mm ²
HD97	Hammer die 97mm ²
HD120	Hammer die 120mm ²
HD150	Hammer die 150mm ²
HD185	Hammer die 185mm ²
HD240	Hammer die 240mm ²
510P	Empty tool box
CAP	Cathodic weld cap (for MCPT joint)



Safety accessories

Part number	Item description
SAFEG	Safety goggles
SAFEGL	Safety gloves
SAFEA	Safety apron (leather)



Exothermic welding must be used in accordance with instructions and with all safety precautions taken. This includes the use of personal protective equipment (PPE).

We run operator training courses to train field operatives on how to safely carry out an exothermic weld.

Exothermic welding toolkit

Part number	Item description
KWTKIT	Toolkit comprising: conductor cleaning brush, safety goggles, plastic tool box, spare flints, sealing putty, safety gloves, mould cleaning brush, minor burn kit, flint ignitor, safety apron (leather), earth rod driving cap (M16), handle clamp (cathodic protection), handle clamp (for type D moulds), handle clamp (for type E/F moulds), mould scraper (to suit C moulds), mould scraper (to suit D moulds) and mould support clamp



All essential safety and operational items to carry out an exothermic weld. Each toolkit (*order KWTKIT*) contains the items listed in the table above.

Handle Clamps

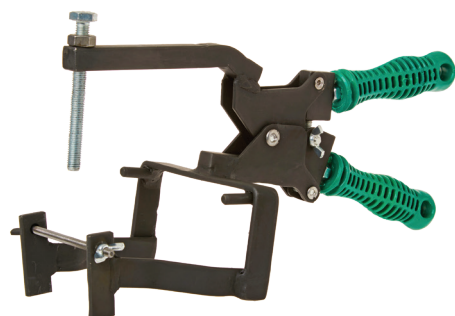

Part number	Item description
HCD	Handle Clamp for use on D type moulds
HCE	Handle Clamp for use on E and F type moulds
HCCP75	Handle Clamp cathodic protection
HCCP100	Handle Clamp cathodic protection
HCC1	Chain Handle/Support Clamp
FRAME	Conductor Support Clamp



Handle Clamps for rail applications

Part number	Item description
HCRC300	Rail crown double mould Support Clamp (157 to 320mm)
HCRC370	Rail crown double mould Support Clamp (175 to 260mm)
HCRS	Rail crown single mould Support Clamp
HCRW	Rail web Handle Clamp
HCCP75	Rail foot Handle Clamp
HCCP100	Rail foot Handle Clamp

Earth Points

A range of Earth Points are available to cover a variety of applications.

They are available with single, twin and four holes. Earth Points can also be supplied with, and without, plates to accommodate different conductors.

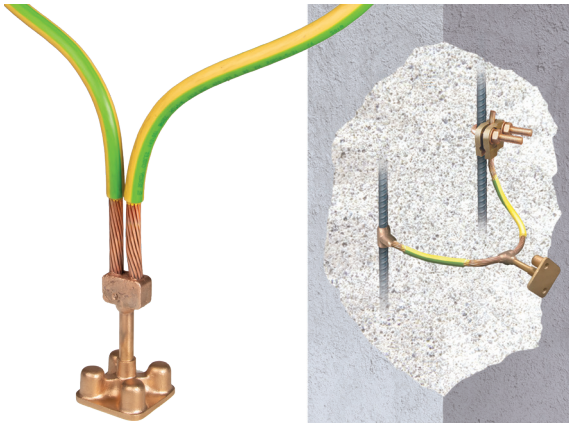

Earth Points (with green/yellow tail)

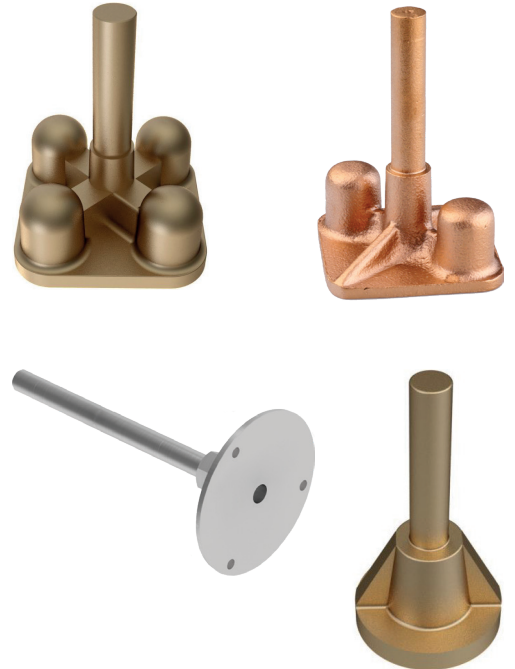

Earth Points (without cover plate)



Single Hole Earth Points (with solid tail)

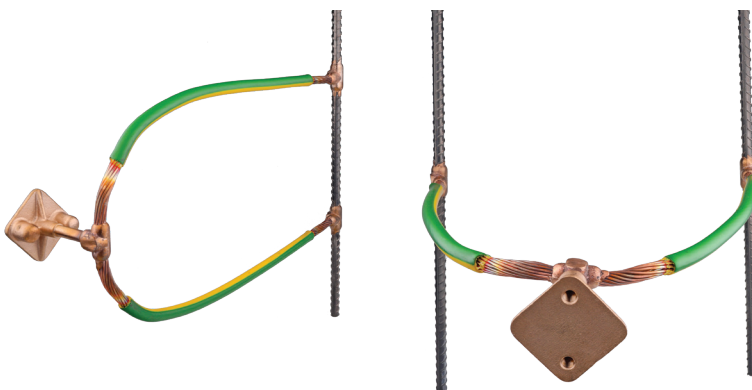

Pre-Welded Rebar/Earth Points



Earth Points (with cover plate)

For details of the Kingsmill range of Earth Points see the BONDING section (pages BOND:7 - 8).

Legend

Icons used throughout this catalogue denote the different elements that make up a KingsWeld connection.



Conductor size

The size of conductors to be joined are denoted by **A** and **B** (where applicable). Bar is denoted by its x and y dimensions. Circular conductors are stranded (cable) or solid (ground rod, rebar). Where both stranded and solid circular conductors can be used these are noted in the relevant table footer. Dimensions are given in mm (diameter) unless otherwise stated.



Price key

Moulds are priced in bands according to their size and complexity. These are denoted by the price key.



Weld metal

Weld metal is sized specifically for each mould. In most cases a single weld metal carton is required. In cases where multiple cartons are required these are denoted by a multiplier (eg 2 x #150).



Clamp

Each KingsWeld mould type requires a specific clamp. If ordering multiple moulds that utilise the same clamp you only need to purchase a quantity of clamps suitable for the number of operators for your application.

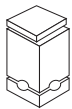

Mould

Mould part numbers are compiled in a logical manner - prefix 'MD' followed by the mould type then followed by size relevant figures (eg CC2 mould to join a 70mm cable to a 50mm cable = MDCC27050).



Sleeve (rail applications)

A copper sleeve that increases the diameter of a small conductor to make it possible to weld the conductor.



Hammer die

A hammer die flattens one side of a conductor giving better contact with the rail. *Used in rail applications.*